

JEDEC
SOLID STATE
PRODUCT OUTLINE

THIS REGISTERED OUTLINE HAS BEEN PREPARED BY THE JEDEC JC-11 COMMITTEE AND REFLECTS A PRODUCT WITH ANTICIPATED USAGE IN THE ELECTRONICS INDUSTRY, CHANGES ARE LIKELY TO OCCUR.

TITLE:
DDR AND DDR2 MICRO DIMM
MEZZANINE 214PIN
0.4mm LEAD CENTERS

DESIGNATOR

ISSUE

DATE

MO-260

SHEET

C

01/07

1 OF 11

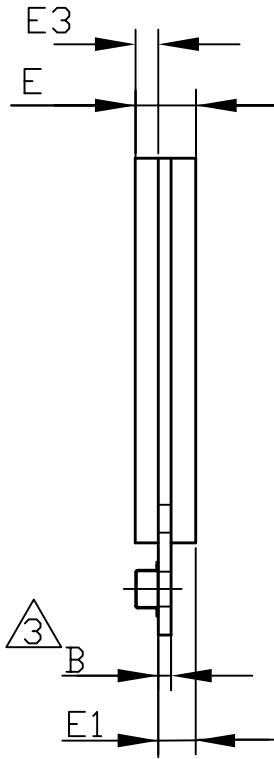

VIEW A-A

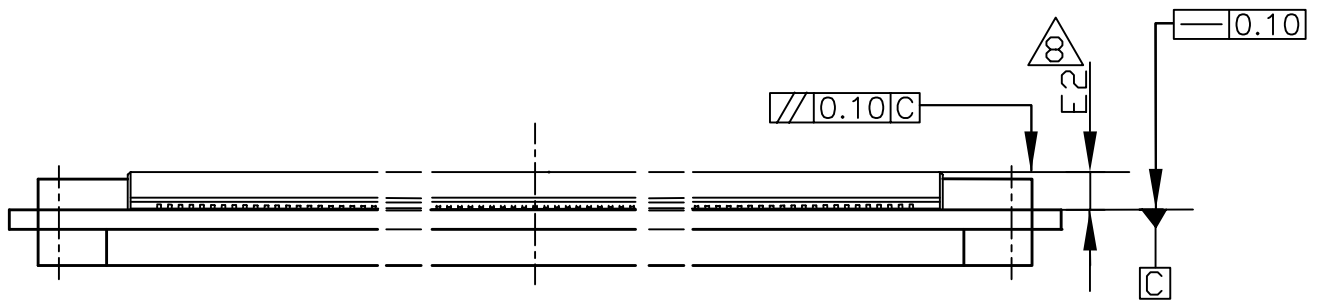

VIEW B-B

<p>JEDEC SOLID STATE PRODUCT OUTLINE</p>	<p>TITLE: DDR AND DDR2 MICRO DIMM MEZZANINE 214PIN 0.4mm LEAD CENTERS</p>	<p>ISSUE C</p>	<p>DATE 01/07</p>	<p>MO-260</p>	<p>SHEET 2 OF 11</p>
--	---	--------------------	-----------------------	---------------	--------------------------

GROUND OR NON-CONNECTION AREA (OUTER LAYERS)

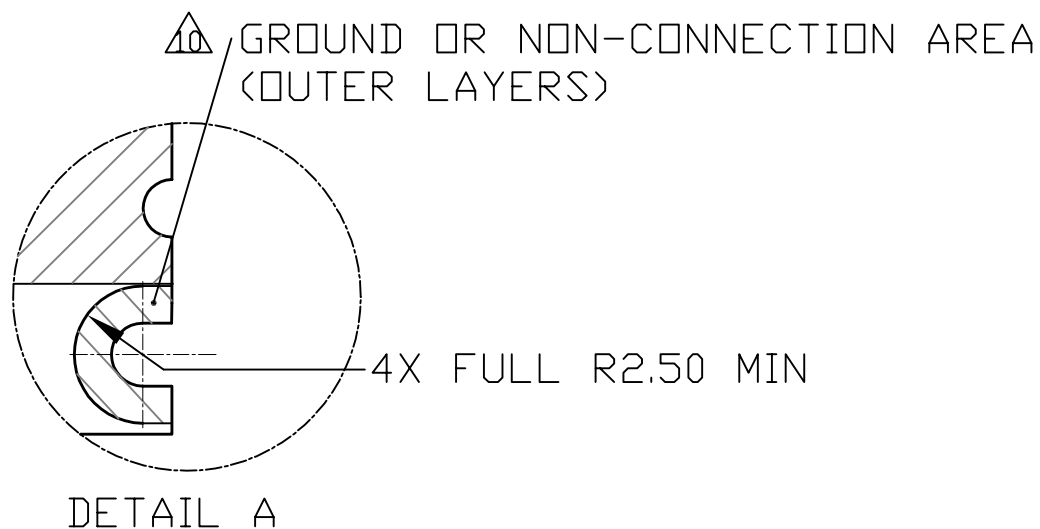
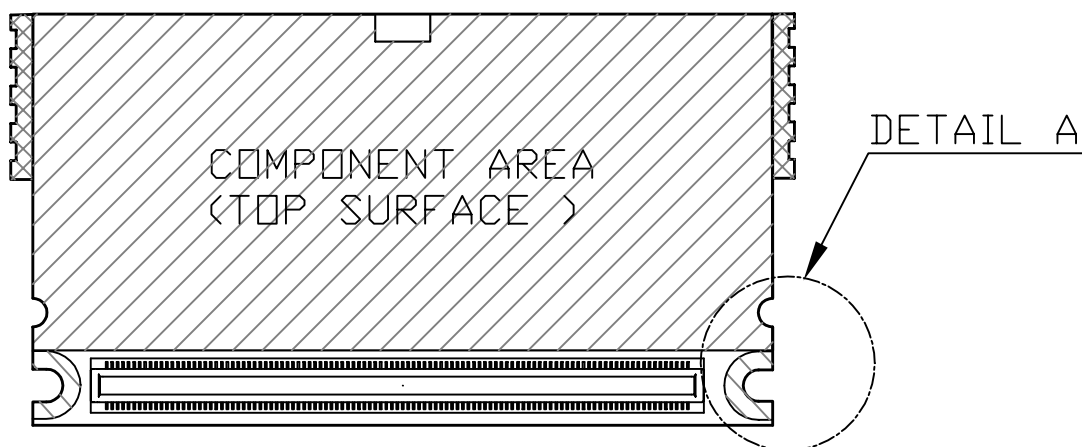

DETAIL A

<p>JEDEC SOLID STATE PRODUCT OUTLINE</p>	<p>TITLE: DDR AND DDR2 MICRO DIMM MEZZANINE 214PIN 0.4mm LEAD CENTERS</p>	<p>ISSUE C</p>	<p>DATE 01/07</p>	<p>MO-260</p>	<p>SHEET 3 OF 11</p>
--	---	--------------------	-----------------------	---------------	--------------------------

GROUND OR NON-CONNECTION AREA (INNER LAYERS)

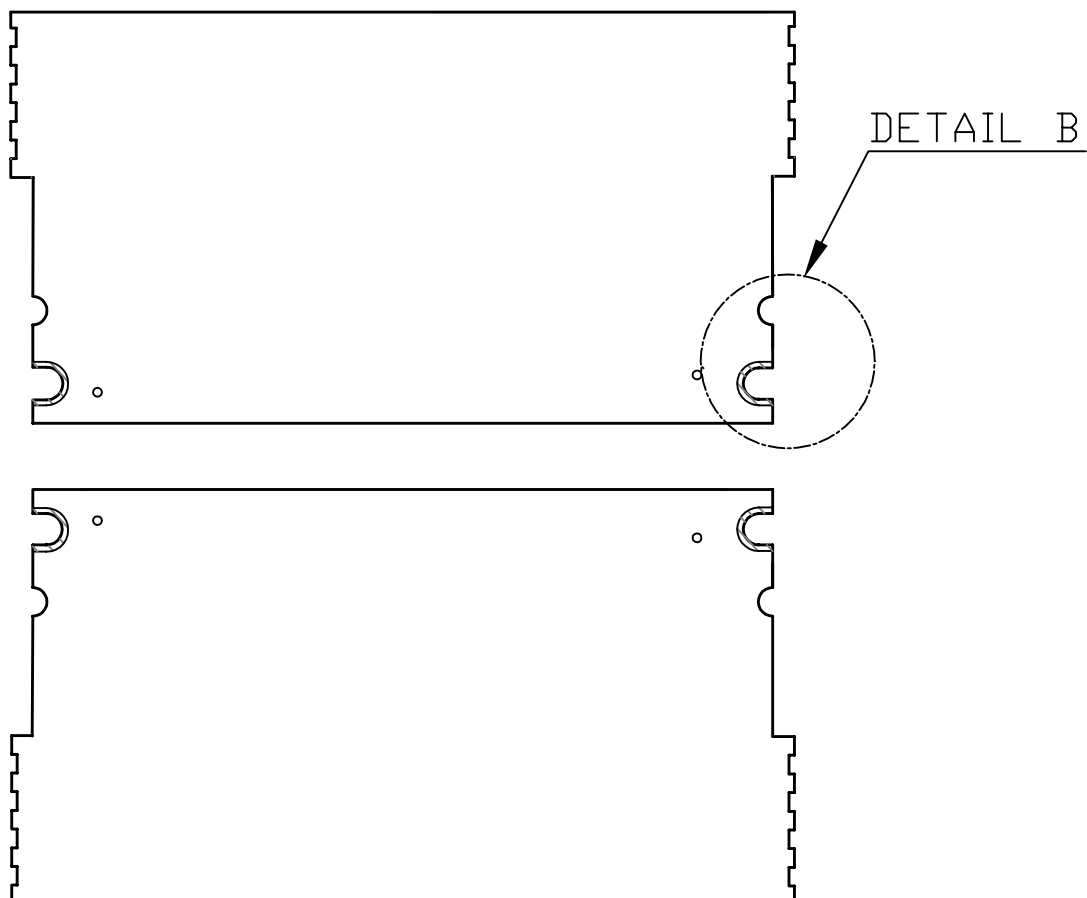

 GROUND OR NON-CONNECTION AREA

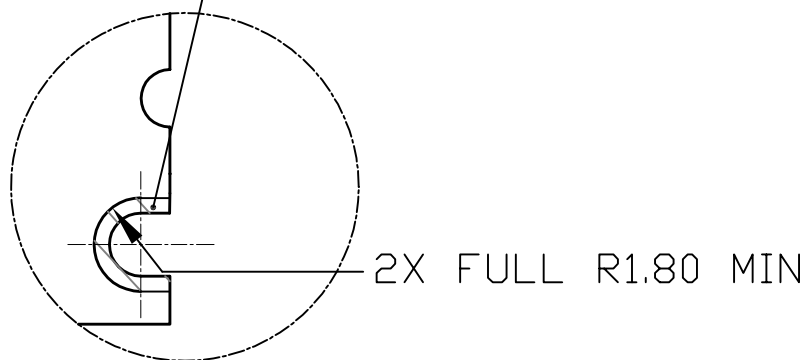

DETAIL B

<p>JEDEC SOLID STATE PRODUCT OUTLINE</p>	<p>TITLE: DDR AND DDR2 MICRO DIMM MEZZANINE 214PIN 0.4mm LEAD CENTERS</p>	<p>ISSUE C</p>	<p>DATE 01/07</p>	<p>MO-260</p>	<p>SHEET 4 OF 11</p>
--	---	--------------------	-----------------------	---------------	--------------------------

MECHANICAL KEYING (VIEW FROM CONNECTOR SIDE)

VAR	VDD (SYSTEM)	
A	$\triangle 4$ 2.5V, 2.6V (DDR) (DETAIL C)	
B	$\triangle 4$ 1.8V (DDR2) (DETAIL D)	
C	$\triangle 4$ 1.5V (DDR3) (DETAIL E)	

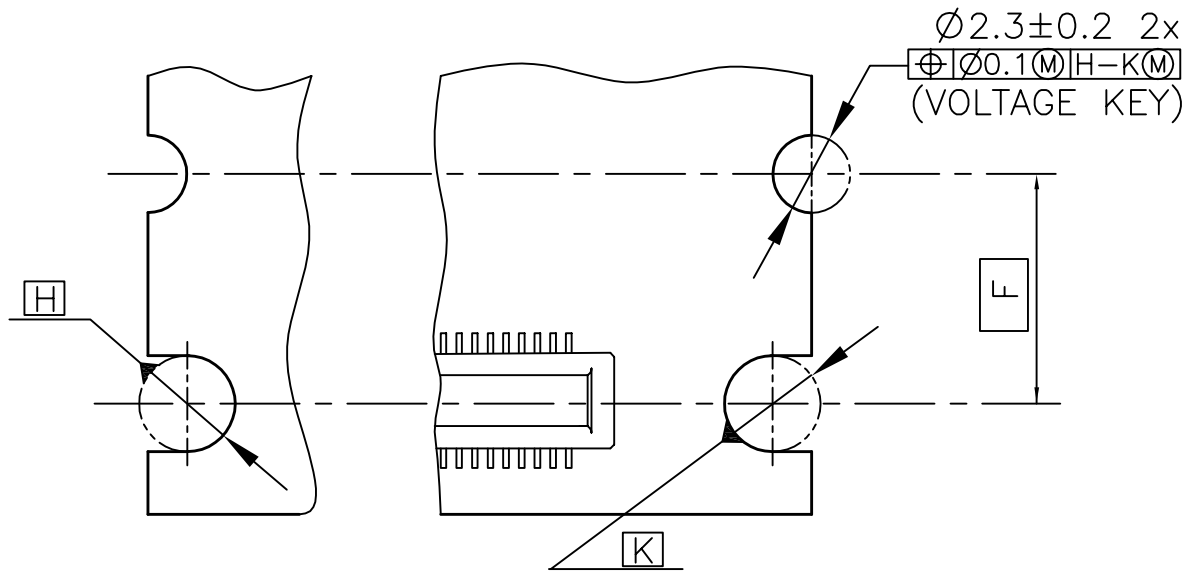

KEY POSITION OF DDR

VARIATION A DETAIL C

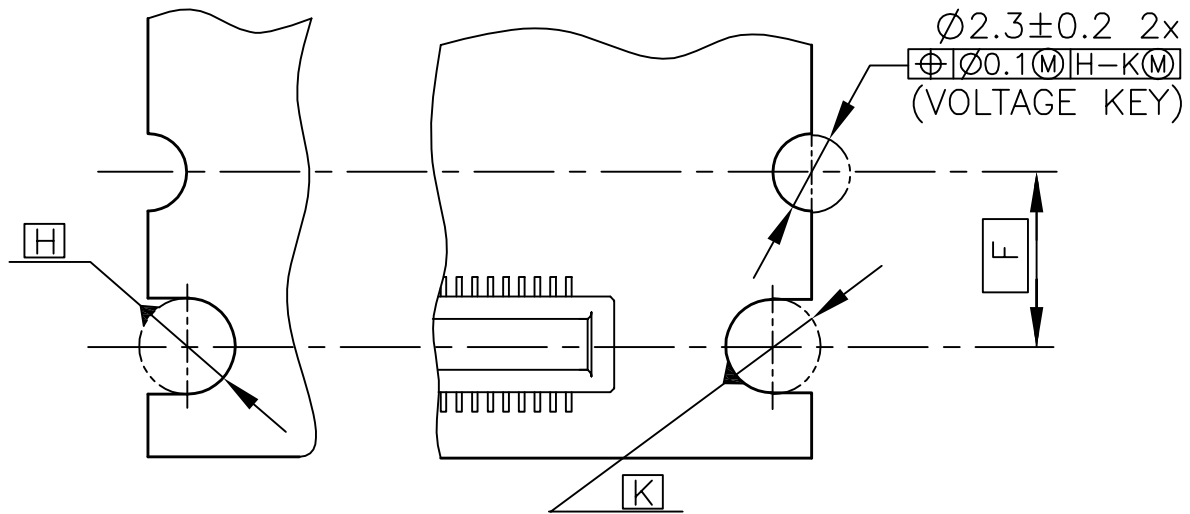

KEY POSITION OF DDR2

VARIATION B DETAIL D

<p>JEDEC SOLID STATE PRODUCT OUTLINE</p>	<p>TITLE: DDR AND DDR2 MICRO DIMM MEZZANINE 214PIN 0.4mm LEAD CENTERS</p>	<p>ISSUE C</p>	<p>DATE 01/07</p>	<p>MO-260</p>	<p>SHEET 6 OF 11</p>
--	---	--------------------	-----------------------	---------------	--------------------------

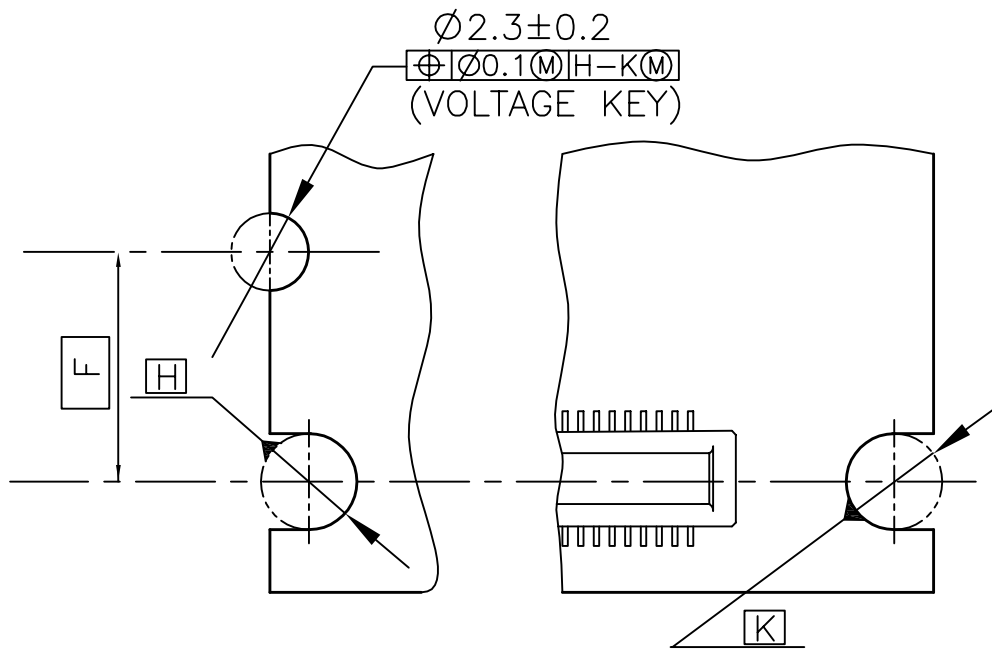

KEY POSITION OF DDR3

VARIATION C DETAIL E

JEDEC SOLID STATE PRODUCT OUTLINE	TITLE: DDR AND DDR2 MICRO DIMM MEZZANINE 214PIN 0.4mm LEAD CENTERS	ISSUE C	DATE 01/07	MO-260	SHEET 7 OF 11
---	---	------------	---------------	--------	------------------

COMMON DIMMENSION TABLE

SYMBOL	MIN	NOM	MAX	NOTES
E	—	—	3.80	
E1	—	—	2.30	
E2	1.40	—	1.65	
E3	—	—	1.50	
A	29.85	30.0	30.15	
A1	5.40	—	—	
A2	2.9 BSC			
D	—	—	58.85	
D1	53.85	54.0	54.15	
D2	52 BSC			
D3	0.4 BSC			
h1	43.36	43.38	43.40	
h2	1.28	1.3	1.32	
NOTES	1,2,3,4,5,6,7 and 9			
REF	14-065			
ISSUE	A			

VARIATIONS

VAR	A			B			C		
SYMBOL	MIN	NOM	MAX	MIN	NOM	MAX	MIN	NOM	MAX
B	0.72	0.80	0.88	0.72	0.80	0.88	0.90	1.00	1.10
F	6.3 BSC			4.3 BSC			8.3 BSC		
NOTES	1,2,3,4,5,6,7 and 9								
REF	14-101								
ISSUE	C								

JEDEC SOLID STATE PRODUCT OUTLINE	TITLE: DDR AND DDR2 MICRO DIMM MEZZANINE 214PIN 0.4mm LEAD CENTERS	ISSUE C	DATE 01/07	MO-260	SHEET 8 OF 11
---	---	------------	---------------	--------	------------------

NOTE

1. DIMENSIONING AND TOLERANCING CONFORM TO ASME Y14.5M-1994.

2. ALL DIMENSIONS ARE IN mm.

3. CARD THICKNESS INCLUDES PLATING AND/OR METALIZATION.

4. THE JC-45 COMMITTEE CONTROLS THIS INFORMATION. IT IS SHOWN HERE FOR REFERENCE ONLY, AND IS SUBJECT TO CHANGE.

5. WHEN OPTIONAL EARS EXIST "D" IS CONTROLLING AND WHEN OPTIONAL EARS DO NOT EXIST "D" DOES NOT APPLY.

6. "h2" DIMENSION APPLIES AT THE BOTTOM OF CONTACT. TOP PORTION OF CONTACT HOUSING, EXCEPT OF HOUSING CORNER AND SIDE HOUSING OF LONGITUDINAL DIRECTION, IS ALLOWED TO INCLINE TOWARDS INSIDE WITHIN 0.05mm MAXIMUM.

7. COMPONENT AREA SHALL BE A MINIMUM OF 0.05mm FROM THE EDGES OF MODULE BOARD.

8. E2 IS HEIGHT OF CONNECTOR.

9. REFER TO SO-004 FOR CONNECTOR OUTLINE INCLUDING VOLTAGE KEY PIN HEIGHT.

JEDEC SOLID STATE PRODUCT OUTLINE	TITLE: DDR AND DDR2 MICRO DIMM MEZZANINE 214PIN 0.4mm LEAD CENTERS	ISSUE C	DATE 01/07	MO-260	SHEET 9 OF 11
---	---	------------	---------------	--------	------------------

△10 THE SUPPORT PARTS AREA FOR THE SCREW STOP ON THE MOTHER BOARD ARE PERMITTED FOR CONNECTION TO GROUND OR NON-CONNECTION ONLY. THE CONNECTION WITH ANY POWER PLANE IS PROHIBITED.

JEDEC SOLID STATE PRODUCT OUTLINE	TITLE: DDR AND DDR2 MICRO DIMM MEZZANINE 214PIN 0.4mm LEAD CENTERS	ISSUE C	DATE 01/07	MO-260	SHEET 10 OF 11
---	---	------------	---------------	--------	-------------------

Change Record

If the changes involves any words added or deleted (excluding deletion of accidentally repeated words), the change is included. Punctuation chages may or may not be included.

Initial Issue:	Date: Feb. '05	Item: 11.14-065
----------------	----------------	-----------------

Revision History:

Issue: B	Date: Sep. '05	Item: 11.14-079
----------	----------------	-----------------

Location	Change from:	Change to:
Page 1 of 10, Around notch for lock screw	Not exist Ground or Non-connection area	Added Gound or Non-Connection Area
Page 2, Table for Dimension	D4 : 43.75 BSC	Deleted (Typo correction)
Page 3	-	Added new page for Ground or Non-Connection Area Detail
Page 4	-	Added new page for Non Metalization Area Detail
Page 8, Note 9	SO-XXX(item14-076)	SO-004
Page 9, Note 10	-	Added new page and Note 10
Page 10	-	Added new page and Note 10

Issue: C	Date: Dec. '06	Item: 11.14-101
----------	----------------	-----------------

Location	Change from:	Change to:
Page 2, PCB thickness	0.8±0.08	B
Page 5, Mechanical Keying	-	Added row for variation A to C, Added drawing of variation C (Detail E) for DDR3
Page 6	DETAIL C	VARIATION A DETAIL C
	DETAIL D	VARIATION B DETAIL D
	6.3, 4.3	F
Page 7	-	Added new page for VARIATION C DETAIL E
Page 8	-	Added variation B and C in table Added a column for F BSC

JEDEC SOLID STATE PRODUCT OUTLINE	TITLE: DDR AND DDR2 MICRO DIMM MEZZANINE 214PIN 0.4mm LEAD CENTERS	ISSUE C	DATE 01/07	MO-260	SHEET 11 OF 11
---	---	------------	---------------	--------	-------------------