



Product Specifications

PART NO: **VL493T5663D-E6M/D5M/CCM**

REV: **1.4**

General Information

2GB 256Mx72 DDR2 SDRAM ECC 200 PIN SO-RDIMM

Description: The VL493T5663D is 256M X 72 Double Data Rate DDR2 SDRAM high density SO-RDIMM. This memory module consists of eighteen CMOS 128Mx8 bit with 8 banks DDR2 Synchronous DRAMs in BGA packages, two 25-bit Registered buffers in BGA package, a zero delay PLL clock in BGA package, and a 2K EEPROM in 8-pin MLF package. This module is a 200-pin small-outline dual in-line memory module and is intended for mounting into a connector socket. Decoupling capacitors are mounted on the printed circuit board for each DDR2 SDRAM.

Features:

- 200-pin, registered small-outline dual in-line memory module (SO-RDIMM)
- JEDEC pin out
- Supports ECC error detection and correction
- On memory PLL Clock
- Data transfer rates: PC2-5300, PC2-3200 or PC2-4200
- Utilizes 1Gbit DDR2 SDRAM components
- Performance range: 400Mb/sec/pin, 533Mb/sec/pin, or 667Mb/sec/pin
- Power supply: Vdd = Vddq = 1.8V ± 0.1V
- JEDEC standard 1.8V I/O (SSTL_18-compatible)
- On-die termination (ODT)
- Differential data strobe (DQS, DQS#) option
- Differential clock inputs (CK, CK#)
- 7.8us average periodic refresh interval
- Programmable CAS# Latency: 5 (DDR2-667), 4 (DDR2-533) and 3 (DDR2-400)
- Posted CAS# additive Latency: 0, 1, 2, 3, and 4
- Eight internal banks for concurrent operation (component)
- Serial presence detect (SPD) with EEPROM
- Lead-free, RoHS compliant
- Gold-edge contacts
- PCB: Height 29.85mm (1.175"), double sided components

Pin Name	Function
A0~A13	Address Inputs
BA0~BA2	Bank Address Inputs
DQ0~DQ63	Data Input/Output
CB0~CB7	Check Bits
DQS0~DQS8	Data Strobes
DQS0#~DQS8#	Data Strobes Complement
ODT0,ODT1	On-die Termination Control
CK,CK#	Clock Input
CKE0,CKE1	Clock Enables
CS0#, CS1#	Chip Selects
RAS#	Row Address Strobes
CAS#	Column Address Strobes
WE#	Write Enable
RESET#	Register Reset Input
DM0~DM8	Data Masks
VDD	Voltage Supply 1.8V +/- 0.1V
A10/AP	Address input/Autoprecharge
VDDSPD	SPD Voltage supply 1.7V to 3.6V
VSS	Ground
SA0~SA1	SPD Address
SDA	SPD Data Input/Output
SCL	SPD Clock Input
VREF	SSTL_18 Reference Voltage
NC	No Connect

Order Information:

VL493T5663D-E6 M

DRAM MANUFACTURER
M - MICRON

MODULE SPEED
E6: PC2-5300 @ CL5
D5: PC2-4200 @ CL4
CC: PC2-3200 @ CL3

VL : Lead-free/RoHS



Product Specifications

PART NO: **VL493T5663D-E6M/D5M/CCM**

REV: **1.4**

Pin Configuration

200-PIN DDR2 SO-RDIMM FRONT								200-PIN DDR2 SO-RDIMM BACK							
Pin	Name	Pin	Name	Pin	Name	Pin	Name	Pin	Name	Pin	Name	Pin	Name		
1	VREF	51	DQ18	101	VDD	151	VSS	2	VSS	52	VSS	102	A6	152	VSS
3	DQ0	53	DQ19	103	A5	153	DQS5#	4	DQ4	54	DQ28	104	A4	154	DM5
5	VSS	55	VSS	105	A3	155	DQS5	6	DQ5	56	DQ29	106	VDD	156	VSS
7	DQ1	57	DQ24	107	A2	157	VSS	8	VSS	58	VSS	108	A1	158	DQ46
9	DQS0#	59	DQ25	109	VDD	159	DQ42	10	DM0	60	DM3	110	A0	160	DQ47
11	DQS0	61	VSS	111	A10/AP	161	DQ43	12	VSS	62	VSS	112	BA1	162	VSS
13	VSS	63	DSQ3#	113	BA0	163	VSS	14	DQ6	64	DQ30	114	VDD	164	DQ52
15	DQ2	65	DSQ3	115	RAS#	165	DQ48	16	DQ7	66	DQ31	116	WE#	166	DQ53
17	DQ3	67	VSS	117	VDD	167	DQ49	18	VSS	68	VSS	118	CS0#	168	VSS
19	VSS	69	DQ26	119	CAS#	169	VSS	20	DQ12	70	CB4	120	ODT0	170	DM6
21	DQ8	71	DQ27	121	CS1#	171	DQS6#	22	DQ13	72	CB5	122	A13	172	VSS
23	DQ9	73	VSS	123	VDD	173	DQS6	24	VSS	74	VSS	124	VDD	174	DQ54
25	VSS	75	CB0	125	ODT1	175	VSS	26	DM1	76	DM8	126	CK	176	DQ55
27	DQS1#	77	CB1	127	NC/ CS3#	177	DQ50	28	VSS	78	VSS	128	CK#	178	VSS
29	DSQ1	79	VSS	129	DQ32	179	DQ51	30	DQ14	80	CB6	130	VSS	180	DQ60
31	VSS	81	DQS8#	131	VSS	181	VSS	32	DQ15	82	CB7	132	DQ36	182	DQ61
33	DQ10	83	DQS8	133	DQ33	183	DQ56	34	VSS	84	VSS	134	DQ37	184	VSS
35	DQ11	85	VSS	135	DQS4#	185	DQ57	36	DQ20	86	CB2	136	VSS	186	DM7
37	VSS	87	CKE0	137	DQS4	187	VSS	38	DQ21	88	CB3	138	DM4	188	DQ62
39	DQ16	89	CKE1	139	VSS	189	DQS7#	40	VSS	90	VSS	140	VSS	190	VSS
41	DQ17	91	NC/ CS2#	141	DQ34	191	DQS7	42	RESET#	92	BA2	142	DQ38	192	DQ63
43	VSS	93	VDD	143	DQ35	193	DQ58	44	DM2	94	NC	144	DQ39	194	SDA
45	DQS2#	95	A12	145	VSS	195	VSS	46	VSS	96	A11	146	VSS	196	SCL
47	DQS2	97	A9	147	DQ40	197	DQ59	48	DQ22	98	VDD	148	DQ44	198	SA1
49	VSS	99	A7	149	DQ41	199	VDDSPD	50	DQ23	100	A8	150	DQ45	200	SA0

Note: 1. CS2#, CS3# (pins 91, 127) are used for 4 rank DIMMs

2. RESET (pin 42) RESET is connected to both OE of the PLL and Reset of the register for 72-bit Registered SO-RDIMM ONLY



Product Specifications

PART NO:

VL493T5663D-E6M/D5M/CCM

REV: 1.4

Functional Block Diagram

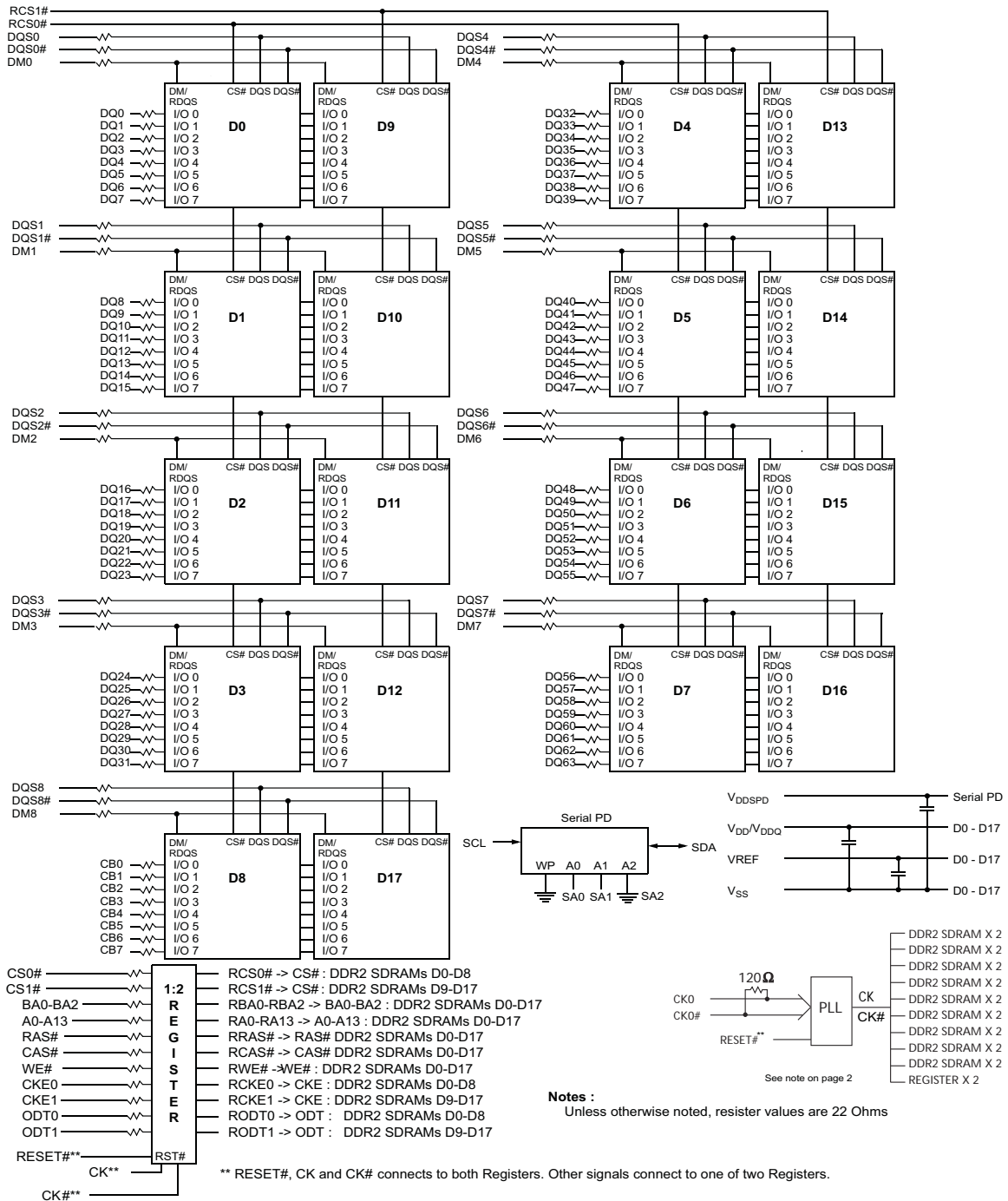



Product Specifications

PART NO:

VL493T5663D-E6M/D5M/CCM

REV: 1.4

Absolute Maximum Ratings

Symbol	Parameter	MIN	MAX	Unit	
V _{DD}	Voltage on V _{DD} pin relative to V _{SS}	-1.0	2.3	V	
V _{DDQ}	Voltage on V _{DDQ} pin relative to V _{SS}	-0.5	2.3	V	
V _{DDL}	Voltage on V _{DDL} pin relative to V _{SS}	-0.5	2.3	V	
V _{IN} , V _{OUT}	Voltage on any pin relative to V _{SS}	-0.5	2.3	V	
T _{STG}	Storage temperature	-55	150	°C	
I _L	Input leakage current; Any input 0V<V _{IN} <V _{DD} ; V _{REF} input 0V<V _{IN} <0.95V; Other pins not under test = 0V	Command/Address, RAS#, CAS#, WE#, CS#, CKE, ODT	-5	5	µA
		CK, CK#	-250	250	µA
		DM	-10	10	µA
I _{oz}	Output leakage current; 0V<V _{OUT} <V _{DDQ} ; DQs and ODT are disabled	-10	10	µA	
I _{VREF}	V _{REF} leakage current; V _{REF} = Valid V _{REF} level	-36	36	µA	

DC Operating Conditions

All voltages referenced to V_{SS}

Parameter	Symbol	Min	Typical	Max	Unit	Notes
Supply voltage	V _{DD}	1.7	1.8	1.9	V	1
I/O Supply voltage	V _{DDQ}	1.7	1.8	1.9	V	4
VDDL Supply voltage	V _{DDL}	1.7	1.8	1.9	V	4
I/O Reference voltage	V _{REF}	0.49 x V _{DDQ}	0.50 x V _{DDQ}	0.51 x V _{DDQ}	V	2
I/O Termination voltage	V _{TT}	V _{REF} -0.04	V _{REF}	V _{REF} +0.04	V	3

- Notes:
- V_{DD}, V_{DDQ} must track each other. V_{DDQ} must be less than or equal to V_{DD}.
 - V_{REF} is expected to equal V_{DDQ}/2 of the transmitting device and to track variations in the DC level of the same. Peak-to-peak noise on V_{REF} may not exceed +/-1percent of the DC value. Peak-to-peak AC noise on V_{REF} may not exceed +/-2 percent of V_{REF}. This measurement is to be taken at the nearest V_{REF} bypass capacitor.
 - V_{TT} is not applied directly to the device. V_{TT} is a system supply for signal termination resistors, is expected to be set equal to V_{REF} and must track variations in the DC level of V_{REF}.
 - V_{DDQ} tracks with V_{DD}; V_{DDL} tracks with V_{DD}.



Product Specifications

PART NO: **VL493T5663D-E6M/D5M/CCM**

REV: **1.4**

Operating Temperature Condition

Parameter	Symbol	Rating	Units	Notes
Operating temperature	TOPER	0 to 85	°C	1,2

Notes:

- Operating temperature is the case surface temperature on the center/top side of the DRAM. For the measurement conditions, please refer to JEDEC JESD51.2
- At 0 to 85°C, operation temperature range, all DRAM specifications will be supported.

Input DC Logic Level

All voltages referenced to VSS

Parameter	Symbol	Min	Max	Unit
Input High (Logic 1) Voltage	VIH(DC)	VREF + 0.125	VDDQ + 0.300	V
Input Low (Logic 0) Voltage	VIL(DC)	-0.300	VREF - 0.125	V

Input AC Logic Level

All voltages referenced to VSS

Parameter	Symbol	Min	Max	Unit
AC Input High (Logic 1) Voltage DDR2-400 & DDR2-533	VIH(AC)	VREF + 0.250	-	V
AC Input High (Logic 1) Voltage DDR2-667	VIH(AC)	VREF + 0.200	-	V
AC Input Low (Logic 0) Voltage DDR2-400 & DDR2-533	VIL(AC)	-	VREF - 0.250	V
AC Input Low (Logic 0) Voltage DDR2-667	VIL(AC)	-	VREF - 0.200	V

Input/Output Capacitance

TA=25°C, f=100MHz

Parameter	Symbol	Min	Max	Unit
Input capacitance (A0~A13, BA0~BA2, RAS#,CAS#,WE#)	CIN1	6.5	7.5	pF
Input capacitance (CKE0,CKE1), (ODT0,ODT1)	CIN2	6.5	7.5	pF
Input capacitance (CS0# ~ CS1#)	CIN3	6.5	7.5	pF
Input capacitance (CK, CK#)	CIN4	6	7	pF
Input capacitance (DM0 ~ DM8), (CB0 ~ CB7)	CIN5	9	12	pF
Input capacitance (DQ0 ~ DQ63), (DQS0 ~ DQS8)	COUT1	9	12	pF



Product Specifications

PART NO: VL493T5663D-E6M/D5M/CCM

REV: 1.4

IDD Specification

Condition	Symbol	-E6	-D5	-CC	Unit
Operating one bank active-precharge; $t_{CK} = t_{CK(IDD)}$; $t_{RC} = t_{RC(IDD)}$; $t_{RAS} = t_{RAS\ MIN(IDD)}$; CKE is HIGH, CS# is HIGH between valid commands; Address bus inputs are SWITCHING; Data bus inputs are SWITCHING	IDD0*	1328	1193	1193	mA
Operating one bank active-read-precharge; IOUT = 0mA; BL = 4; CL = CL(IDD); $t_{CK} = t_{CK(IDD)}$; $t_{RC} = t_{RC(IDD)}$; $t_{RAS} = t_{RAS\ MIN(IDD)}$; CKE is HIGH, CS# is HIGH between valid commands; Address bus inputs are SWITCHING; Data bus inputs are SWITCHING; Data pattern is same as IDD4W.	IDD1*	1463	1418	1373	mA
Precharge power-down current; All banks idle; $t_{CK} = t_{CK(IDD)}$; CKE is LOW; Other control and address bus inputs are STABLE; Data bus inputs are FLOATING	IDD2P**	626	626	626	mA
Precharge quiet standby current; All banks idle; $t_{CK} = t_{CK(IDD)}$; CKE is HIGH; CS# is HIGH; Other control and address bus inputs are STABLE; Data bus inputs are FLOATING	IDD2Q**	1220	1220	1130	mA
Precharge standby current; All banks idle; $t_{CK} = t_{CK(IDD)}$; CKE is HIGH; CS# is HIGH; Other control and address bus inputs are STABLE; Data bus inputs are SWITCHING.	IDD2N**	1220	1220	1130	mA
Active power-down current; All banks open; $t_{CK} = t_{CK(IDD)}$; CKE is LOW; Other control and address bus inputs are STABLE; Data bus inputs are FLOATING.	Fast PDN Exit MRS(12) = 0 Slow PDN Exit MRS(12) = 1	1040	1040	1040	mA
		680	680	680	mA
Active standby current; All banks open; $t_{CK} = t_{CK(IDD)}$; $t_{RC} = t_{RC(IDD)}$; $t_{RAS} = t_{RAS\ MIN(IDD)}$; CKE is HIGH, CS# is HIGH between valid commands; Other control and address bus inputs are SWITCHING; Data bus inputs are SWITCHING.	IDD3N**	1490	1310	1220	mA
Operating burst write current; All banks open; Continuous burst writes; BL = 4; CL = CL(IDD); AL = 0; $t_{CK} = t_{CK(IDD)}$; $t_{RAS} = t_{RAS\ MAX(IDD)}$; $t_{RP} = t_{RP(IDD)}$; CKE is HIGH, CS# is HIGH between valid commands; Address bus inputs are SWITCHING; Data bus inputs are SWITCHING.	IDD4W*	1778	1688	1508	mA
Operating burst read current; All banks open; Continuous burst reads; IOUT = 0mA; BL = 4; CL = CL(IDD); AL = 0; $t_{CK} = t_{CK(IDD)}$; $t_{RAS} = t_{RAS\ MAX(IDD)}$; $t_{RP} = t_{RP(IDD)}$; CKE is HIGH, CS# is HIGH between valid commands; Address bus inputs are SWITCHING; Data pattern is same as IDD4W.	IDD4R*	1778	1688	1508	mA
Burst auto refresh current; $t_{CK} = t_{CK(IDD)}$; Refresh command at every $t_{RFC(IDD)}$ interval; CKE is HIGH; CS# is HIGH between valid commands; Other control and address bus inputs are SWITCHING; Data bus inputs are SWITCHING.	IDD5**	4370	4280	4190	mA
Self refresh current; CK and CK# at 0V; CKE < 0.2V; Other control and address bus inputs are FLOATING; Data bus inputs are FLOATING.	Normal IDD6**	126	126	126	mA
Operating bank interleave read current; All bank interleaving reads; IOUT = 0mA; BL = 4; CL = CL(IDD); AL = $t_{RCD(IDD)} - 1 * t_{CK(IDD)}$; $t_{CK} = t_{CK(IDD)}$; $t_{RC} = t_{RC(IDD)}$; $t_{RRD} = t_{RRD(IDD)}$; $t_{RCD} = 1 * t_{CK(IDD)}$; CKE is HIGH; CS# is HIGH between valid commands; Address bus inputs are STABLE during DESELECTs; Data bus inputs are SWITCHING.	IDD7*	3083	2993	2903	mA

Notes: IDDs were calculated using Micron components. Other manufacturers' DRAMs may have different values.
 *: Value calculated as one module rank in this operating condition, and all other module ranks in IDD2P (CKE LOW) mode.
 **: Value calculated reflects all module ranks in this operating condition.



Product Specifications

PART NO:

VL493T5663D-E6M/D5M/CCM

REV: 1.4

AC Timing Parameters & Specifications

Parameter		Symbol	-E6		-D5		-CC		Unit
			Min	Max	Min	Max	Min	Max	
Clock	Clock cycle time	CL=5 $t_{CK}(5)$	3000	8000	-	-	-	-	ps
		CL=4 $t_{CK}(4)$	3750	8000	3,750	8,000	5,000	8,000	ps
		CL=3 $t_{CK}(3)$	5000	8000	5,000	8,000	5,000	8,000	ps
	CK high-level width	t_{CH}	0.48	0.52	0.48	0.52	0.48	0.52	t_{CK}
	CK low-level width	t_{CL}	0.48	0.52	0.48	0.52	0.48	0.52	t_{CK}
	Half clock period	t_{HP}	MIN (t_{CH}, t_{CL})		MIN (t_{CH}, t_{CL})		MIN (t_{CH}, t_{CL})		ps
	Clock jitter	t_{JIT}	-125	125	-125	125	-125	125	ps
Data	DQ output access time from CK/CK#	t_{AC}	-450	+450	-500	+500	-600	+600	ps
	Data-out high impedance window from CK/CK#	t_{HZ}		$t_{AC}(MAX)$		$t_{AC}(MAX)$		$t_{AC}(MAX)$	ps
	Data-out low-impedance window from CK/CK#	t_{LZ}	$t_{AC}(MIN)$	$t_{AC}(MAX)$	$t_{AC}(MIN)$	$t_{AC}(MAX)$	$t_{AC}(MIN)$	$t_{AC}(MAX)$	ps
	DQ and DM input setup time relative to DQS	t_{DS}	100		100		150		
	DQ and DM input hold time relative to DQS	t_{DH}	175		225		275		
	DQ and DM input pulse width (for each input)	t_{DIPW}	0.35		0.35		0.35		t_{CK}
	Data hold skew factor	t_{OHS}		340		400		450	ps
	DQ-DQS hold, DQS to first DQ to go nonvalid, per access	t_{QH}	$t_{HP} - t_{OHS}$		$t_{HP} - t_{OHS}$		$t_{HP} - t_{OHS}$		ps
	Data valid output window (DVW)	t_{DVW}	$t_{QH} - t_{DQSQ}$		$t_{QH} - t_{DQSQ}$		$t_{QH} - t_{DQSQ}$		ns
Data Strobe	DQS input high pulse width	t_{DQSH}	0.35		0.35		0.35		t_{CK}
	DQS input low pulse width	t_{DQSL}	0.35		0.35		0.35		t_{CK}
	DQS output access time from CK/CK#	t_{DQSQ}	-400	+400	-450	+450	-500	+500	ps
	DQS falling edge to CK rising – setup time	t_{DSS}	0.2		0.2		0.2		t_{CK}
	DQS falling edge from CK rising – hold time	t_{DSH}	0.2		0.2		0.2		t_{CK}
	DQS-DQ skew, DQS to last DQ valid, per group, per access	t_{DQSQ}		240		300		350	ps
	DQS read preamble	t_{RPRE}	0.9	1.1	0.9	1.1	0.9	1.1	t_{CK}
	DQS read postamble	t_{RPST}	0.4	0.6	0.4	0.6	0.4	0.6	t_{CK}
	DQS write preamble setup time	t_{WPRES}	0		0		0		ps
	DQS write preamble	t_{WPRE}	0.35		0.25		0.25		t_{CK}
	DQS write postamble	t_{WPST}	0.4	0.6	0.4	0.6	0.4	0.6	t_{CK}
	Write command to first DQS latching transition	t_{DQSS}	WL-0.25	WL+0.25	WL-0.25	WL+0.25	WL-0.25	WL+0.25	t_{CK}



Product Specifications

PART NO: VL493T5663D-E6M/D5M/CCM

REV: 1.4

AC Timing Parameters & Specifications (cont')

Parameter	Symbol	-E6		-D5		-CC		Unit	
		Min	Max	Min	Max	Min	Max		
Command and Address	Address and control input pulse width for each input	t_{PW}	0.6		0.6		0.6		t_{CK}
	Address and control input setup time	t_{IS}	200		250		350		ps
	Address and control input hold time	t_{IH}	275		375		475		ps
	CAS# to CAS# command delay	t_{CCD}	2		2		2		ps
	ACTIVE to ACTIVE (same bank) command	t_{RC}	55		55		55		ns
	ACTIVE bank a to ACTIVE bank b command	t_{RBD}	7.5		7.5		7.5		ns
	ACTIVE to READ or WRITE delay	t_{RCD}	15		15		15		ns
	Four Bank Activate period	t_{FAW}	37.5		37.5		37.5		ns
	ACTIVE to PRECHARGE command	t_{RAS}	40	70,000	40	70,000	40	70,000	ns
	Internal READ to precharge command delay	t_{RTP}	7.5		7.5		7.5		ns
	Write recovery time	t_{WR}	15		15		15		ns
	Auto precharge write recovery + precharge time	t_{DAL}	$t_{WR} + t_{RP}$		$t_{WR} + t_{RP}$		$t_{WR} + t_{RP}$		ns
	Internal WRITE to READ command delay	t_{WTR}	7.5		7.5		10		ns
	PRECHARGE command period	t_{RP}	15		15		15		ns
	PRECHARGE ALL command period	t_{RPA}	$t_{RP} + t_{CK}$		$t_{RP} + t_{CK}$		$t_{RP} + t_{CK}$		ns
	LOAD MODE command cycle time	t_{MRD}	2		2		2		t_{CK}
	CKE low to CK,CK# uncertainty	t_{DELAY}	$t_{IS} + t_{CK} + t_{IH}$		$t_{IS} + t_{CK} + t_{IH}$		$t_{IS} + t_{CK} + t_{IH}$		ns
Self Refresh	REFRESH to Active or Refresh to Refresh command interval	t_{RFC}	127.5	70,000	127.5	70,000	127.5	70,000	ns
	Average periodic refresh interval	t_{REFI}		7.8		7.8		7.8	us
	Exit self refresh to non-READ command	t_{XSNR}	$t_{RFC(MIN)} + 10$		$t_{RFC(MIN)} + 10$		$t_{RFC(MIN)} + 10$		ns
	Exit self refresh to READ	t_{XSRD}	200		200		200		t_{CK}
	Exit self refresh timing reference	t_{ISXR}	t_{IS}		t_{IS}		t_{IS}		ps
ODT	ODT turn-on delay	t_{AOND}	2	2	2	2	2	2	t_{CK}
	ODT turn-on	t_{AON}	$t_{AC(MIN)}$	$t_{AC(MAX)} + 700$	$t_{AC(MIN)}$	$t_{AC(MAX)} + 1000$	$t_{AC(MIN)}$	$t_{AC(MAX)} + 1000$	ps
	ODT turn-off delay	t_{AOFD}	2.5	2.5	2.5	2.5	2.5	2.5	t_{CK}
	ODT turn-off	t_{AOF}	$t_{AC(MIN)}$	$t_{AC(MAX)} + 600$	$t_{AC(MIN)}$	$t_{AC(MAX)} + 600$	$t_{AC(MIN)}$	$t_{AC(MAX)} + 600$	ps
	ODT turn-on (power-down mode)	t_{AONPD}	$t_{AC(MIN)} + 2000$	$2 \times t_{CK} + t_{AC(MAX)} + 1000$	$t_{AC(MIN)} + 2000$	$2 \times t_{CK} + t_{AC(MAX)} + 1000$	$t_{AC(MIN)} + 2000$	$2 \times t_{CK} + t_{AC(MAX)} + 1000$	ps
	ODT turn-off (power-down mode)	t_{AOFPD}	$t_{AC(MIN)} + 2000$	$2.5 \times t_{CK} + t_{AC(MAX)} + 1000$	$t_{AC(MIN)} + 2000$	$2.5 \times t_{CK} + t_{AC(MAX)} + 1000$	$t_{AC(MIN)} + 2000$	$2.5 \times t_{CK} + t_{AC(MAX)} + 1000$	ps
	ODT to power-down entry latency	t_{ANPD}	3		3		3		t_{CK}
	ODT power-down exit latency	t_{AXPD}	8		8		8		t_{CK}
Power-Down	Exit active power-down to READ command, MR[bit12=0]	t_{XARD}	2		2		2		t_{CK}
	Exit active power-down to READ command, MR[bit12=1]	t_{XARDS}	7-AL		6-AL		6-AL		t_{CK}
	Exit precharge power-down to any non-READ command.	t_{XP}	2		2		2		t_{CK}
	CKE minimum high/low time	t_{CKE}	3		3		3		t_{CK}

<h1>Product Specifications</h1>		
PART NO:	VL493T5663D-E6M/D5M/CCM	REV: 1.4

Package Dimensions

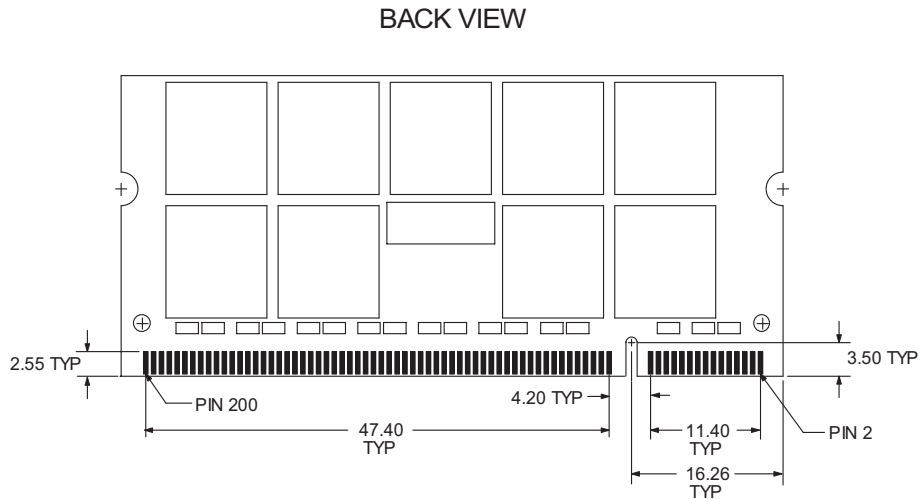
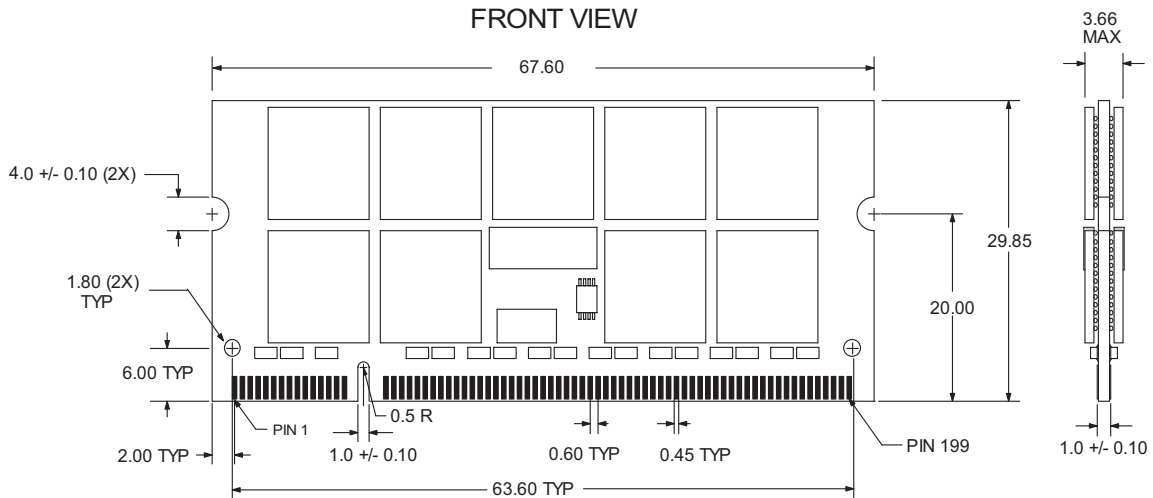

NOTE:

All dimensions are in millimeters with tolerance +/- 0.15mm unless otherwise specified.



Product Specifications

PART NO: **VL493T5663D-E6M/D5M/CCM**

REV: **1.4**

Revision History:

Date	Rev.	Page	Changes
06/25/07	0.1	All	Initial draft
06/30/07	1.0	All	Released spec
10/02/07	1.1	9	Changed thickness of module as 29.85mm instead of 30mm
12/01/08	1.2	1	Added "IPC-610 Class 3"
12/09/08	1.3	9	Updated Dimension Package
08/25/10	1.4	All	Update datasheet