



# Product Specifications

PART NO:

**VL47B5663A-K9S/F8S/E7S-I**

REV: 1.0

## General Information

### 2GB 256MX64 DDR3 UNBUFFERED 204 PIN SODIMM WITH BGA DRAM COMPONENTS

**Description:** The VL47B5663A is a 256Mx64 DDR3 SDRAM high density SODIMM. This memory module consists of sixteen CMOS 128Mx8 bit with 8 banks DDR3 Synchronous DRAMs in BGA packages and a 2K EEPROM with Thermal Sensor in an 8-pin MLF package. This module is a 204-pin small-outline dual in-line memory module and is intended for mounting into a connector socket. Decoupling capacitors are mounted on the printed circuit board for each DDR3 SDRAM.

### Features:

- . 204-pin, small-outline dual in-line memory module (SODIMM)
- . Fast data transfer rates: PC3-10600, PC3-8500, PC3-6400
- . VDD = VDDQ = 1.5V +/- 0.075V
- . VDDSPD = 3V to 3.6V
- . JEDEC standard 1.5V +/- 0.075V I/O (SSTL\_15 compatible)
- . 8 Banks
- . 8-bit pre-fetch architecture
- . Bi-directional Differential Data-Strobe
- . Programmable CAS# Latency: 6, 7, 9
- . Programmable burst; length (8)
- . On-die termination (ODT)
- . Average refresh period 7.8 us
- . Asynchronous Reset
- . Fly-by topology
- . Terminated command, address, and control bus
- . Gold edge PCB
- . Lead-free, RoHS compliant
- . Serial presence detect (SPD) with EEPROM with Thermal Sensor,
- . Thermal sensor range: -20°C to +125°C (+/- 1°C Accuracy)
- . JEDEC pin out
- . PCB: Height 30mm (1.181"), double sided components
- . Operating temperature (TOPER): -40°C to +85°C (module screening using commercial DRAM)

Pin Name	Function
A0~A13	Address Inputs
A10/AP	Address Input/Auto Precharge
BA0~BA2	Bank Address Inputs
DQ0~DQ63	Data Input/Output
DQS0~DQS7	Data Strobes
DQS0#~DQS7#	Data Strobes Complement
ODT0, ODT1	On-die Termination Control
CK0, CK0#, CK1, CK1#	Clock Input
CKE0, CKE1	Clock Enables
CS0#, CS1#	Chip Selects
RAS#	Row Address Strobes
CAS#	Column Address Strobes
WE#	Write Enable
VDD	Voltage Supply 1.5V +/- 0.075V
VSS	Ground
SA0~SA1	SPD Address
SDA	SPD Data Input/Output
SCL	SPD Clock Input
DM0~DM7	Data Masks
VREFCA	Reference Voltage for CA
VREFDQ	Reference Voltage for DQ
VDDSPD	SPD Voltage Supply 3V to 3.6V
VTT	Termination Voltage
RESET#	Register and SDRAM Control
EVENT#	Reserved for Temp Sensing
NC	No Connect

### Order Information:

**VL47B5663A-K9 S X- I**

- I: Screening
- DRAM DIE (option)
- DRAM MANUFACTURER  
S - SAMSUNG
- MODULE SPEED  
K9: PC3-10600 @ CL9  
F8: PC3-8500 @ CL7  
E7: PC3-6400 @ CL6
- VL: Lead-free/RoHS



# Product Specifications

PART NO:

VL47B5663A-K9S/F8S/E7S-I

REV: 1.0

## Pin Configuration

204-PIN DDR3 SODIMM FRONT								204-PIN DDR3 SODIMM BACK							
Pin	Name	Pin	Name	Pin	Name	Pin	Name	Pin	Name	Pin	Name	Pin	Name		
1	VREFDQ	53	DQ19	105	VDD	157	DQ42	2	VSS	54	VSS	106	VDD		
3	VSS	55	VSS	107	A10	159	DQ43	4	DQ4	56	DQ28	108	BA1		
5	DQ0	57	DQ24	109	BA0	161	VSS	6	DQ5	58	DQ29	110	RAS#		
7	DQ1	59	DQ25	111	VDD	163	DQ48	8	VSS	60	VSS	112	VDD		
9	VSS	61	VSS	113	WE#	165	DQ49	10	DQS0#	62	DQS3#	114	CS0#		
11	DM0	63	DM3	115	CAS#	167	VSS	12	DQS0	64	DQS3	116	ODT0		
13	VSS	65	VSS	117	VDD	169	DQS6#	14	VSS	66	VSS	118	VDD		
15	DQ2	67	DQ26	119	A13	171	DQS6	16	DQ6	68	DQ30	120	ODT1		
17	DQ3	69	DQ27	121	CS1#	173	VSS	18	DQ7	70	DQ31	122	NC		
19	VSS	71	VSS	123	VDD	175	DQ50	20	VSS	72	VSS	124	VDD		
21	DQ8	73	CKE0	125	NC	177	DQ51	22	DQ12	74	CKE1	126	VREFCA		
23	DQ9	75	VDD	127	VSS	179	VSS	24	DQ13	76	VDD	128	VSS		
25	VSS	77	NC	129	DQ32	181	DQ56	26	VSS	78	NC	130	DQ36		
27	DQS1#	79	BA2	131	DQ33	183	DQ57	28	DM1	80	NC/A14	132	DQ37		
29	DQS1	81	VDD	133	VSS	185	VSS	30	RESET#	82	VDD	134	VSS		
31	VSS	83	A12	135	DQS4#	187	DM7	32	VSS	84	A11	136	DM4		
33	DQ10	85	A9	137	DQS4	189	VSS	34	DQ14	86	A7	138	VSS		
35	DQ11	87	VDD	139	VSS	191	DQ58	36	DQ15	88	VDD	140	DQ38		
37	VSS	89	A8	141	DQ34	193	DQ59	38	VSS	90	A6	142	DQ39		
39	DQ16	91	A5	143	DQ35	195	VSS	40	DQ20	92	A4	144	VSS		
41	DQ17	93	VDD	145	VSS	197	SA0	42	DQ21	94	VDD	146	DQ44		
43	VSS	95	A3	147	DQ40	199	VDDSPD	44	VSS	96	A2	148	DQ45		
45	DQS2#	97	A1	149	DQ41	201	SA1	46	DM2	98	A0	150	VSS		
47	DQS2	99	VDD	151	VSS	203	VTT	48	VSS	100	VDD	152	DQS5#		
49	VSS	101	CK0	153	DM5			50	DQ22	102	CK1	154	DQS5		
51	DQ18	103	CK0#	155	VSS			52	DQ23	104	CK1#	156	VSS		

Notes: 1. Pin 80 is NC for 1GB and A14 for 2GB component.

## Functional Block Diagram

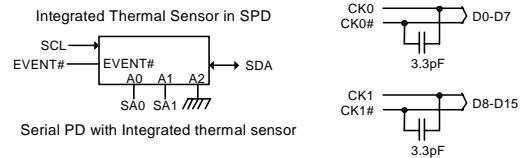
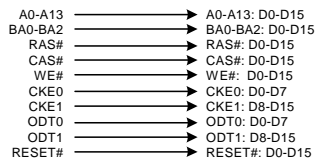
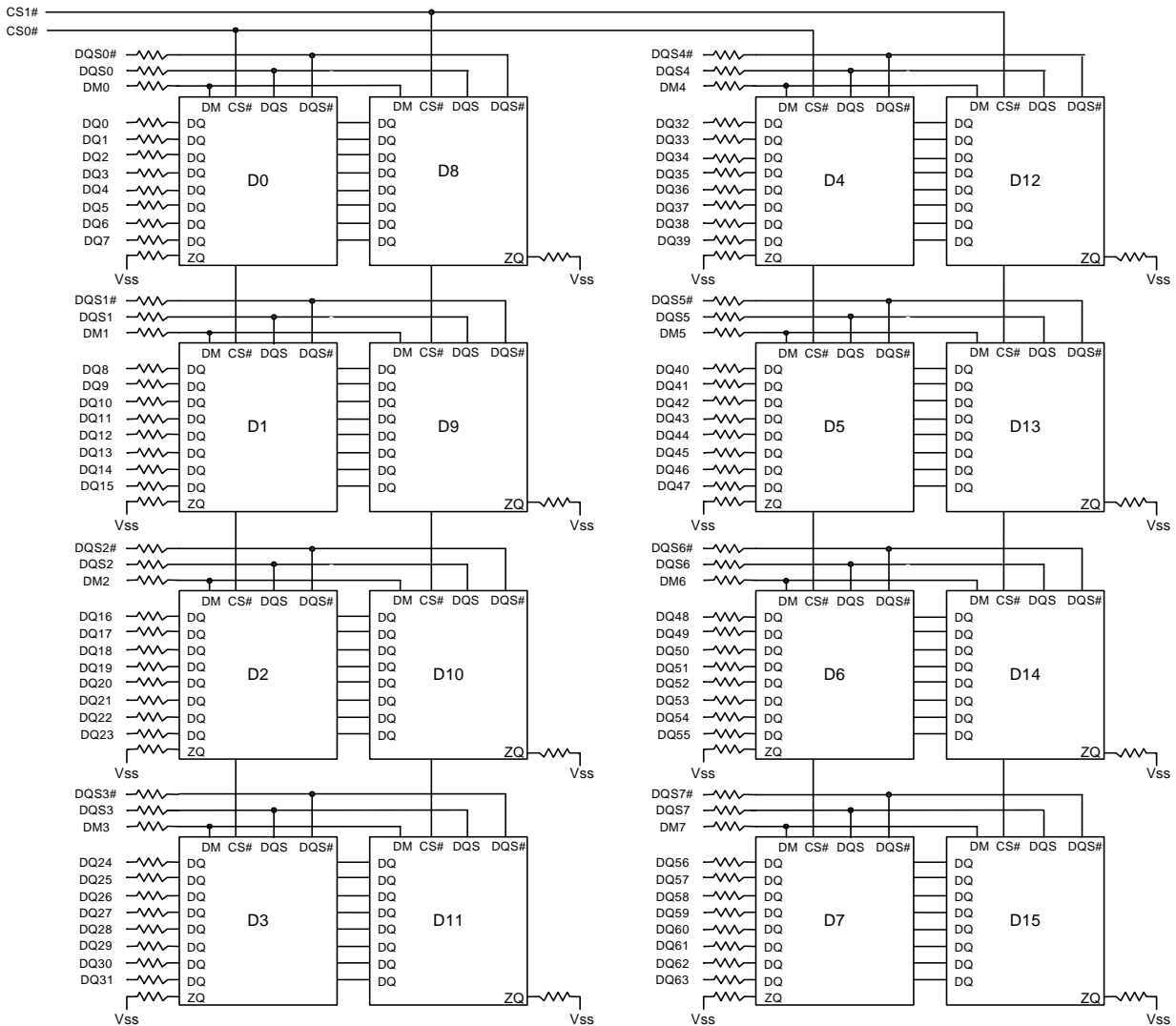

Command, address, control, and clock line terminations

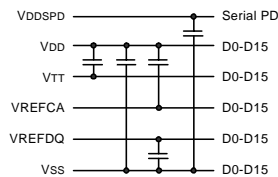
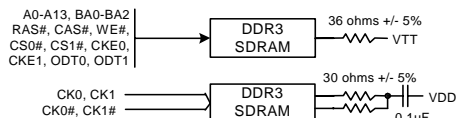

Notes:

1. Unless otherwise noted, resistor values are 15 Ohms +/- 5%
2. ZQ resistors are 240 Ohms +/- 1%



# Product Specifications

PART NO:

VL47B5663A-K9S/F8S/E7S-I

REV: 1.0

## Absolute Maximum Ratings

Symbol	Parameter	MIN	MAX	Unit	
V <sub>DD</sub>	Voltage on V <sub>DD</sub> pin relative to V <sub>SS</sub>	-0.4	1.975	V	
V <sub>DDQ</sub>	Voltage on V <sub>DDQ</sub> pin relative to V <sub>SS</sub>	-0.4	1.975	V	
V <sub>IN</sub> , V <sub>OUT</sub>	Voltage on any pin relative to V <sub>SS</sub>	-0.4	1.975	V	
T <sub>STG</sub>	Storage temperature	-55	100	°C	
I <sub>L</sub>	Input leakage current; Any input 0V<V <sub>IN</sub> <V <sub>DD</sub> ; V <sub>REF</sub> input 0V<V <sub>IN</sub> <0.95V; Other pins not under test = 0V	Command/Address, RAS#, CAS#, WE#, BA	-32	32	µA
		CS#, CKE, ODT	-16	16	µA
		CK, CK#	-16	16	µA
		DM	-4	4	µA
I <sub>oz</sub>	Output leakage current; 0V<V <sub>OUT</sub> <V <sub>DDQ</sub> ; DQs and ODT are disabled	-10	10	µA	
I <sub>VREF</sub>	V <sub>REF</sub> leakage current; V <sub>REF</sub> = Valid V <sub>REF</sub> level	-16	16	µA	

## DC Operating Conditions

Parameter	Symbol	Min	Typical	Max	Unit	Notes
Supply Voltage	V <sub>DD</sub>	1.425	1.5	1.575	V	1,2
Supply Voltage for Output	V <sub>DDQ</sub>	1.425	1.5	1.575	V	1,2
I/O Reference voltage (DQ)	V <sub>REFDQ</sub> (DC)	0.49 x V <sub>DDQ</sub>	0.5 x V <sub>DD</sub>	0.51 x V <sub>DDQ</sub>	V	3,4
I/O Reference voltage (CMD/ADD)	V <sub>REFCA</sub> (DC)	0.49 x V <sub>DDQ</sub>	0.5 x V <sub>DD</sub>	0.51 x V <sub>DDQ</sub>	V	3,4
Termination Reference Voltage	V <sub>TT</sub>	-0.483 x V <sub>DD</sub>	0.5 x V <sub>DD</sub>	+0.517 x V <sub>DD</sub>	V	5

- Notes:
- Under all conditions V<sub>DDQ</sub> must be less than or equal to V<sub>DD</sub>.
  - V<sub>DDQ</sub> tracks with V<sub>DD</sub>. AC parameters are measured with V<sub>DD</sub> and V<sub>DDQ</sub> tied together.
  - The ac peak noise on V<sub>REF</sub> may not allow V<sub>REF</sub> to deviate from V<sub>REF</sub>(DC) by more than +/- 1% V<sub>DD</sub>.
  - For reference: approximate V<sub>DD</sub>/2 +/- 15mV.
  - V<sub>TT</sub> termination voltage in excess of stated limit will adversely affect the command and address signals' voltage margin and will reduce timing margins.

## Operating Temperature Condition

Parameter	Symbol	Rating	Units	Notes
Operating temperature	TOPER	-40 to +85	°C	1, 2

- Notes:
- Operating temperature is the case surface temperature on the center/top side of the DRAM. For the measurement conditions, please refer to JEDEC JESD5-2.
  - At -40 to +85°C, operation temperature range, all DRAM specifications will be supported. The refresh rate is required to double when 85°C < TOPER <= 95°C



# Product Specifications

PART NO:

VL47B5663A-K9S/F8S/E7S-I

REV: 1.0

## Input DC Logic Level

All voltages referenced to VSS

Parameter	Symbol	Min	Max	Unit
<b>Command and Address</b>				
Input High (Logic 1) Voltage DDR3-800/1066/1333	VIHCA(DC)	VREF + 0.100	VDD	V
Input Low (Logic 0) Voltage DDR3-800/1066/1333	VILCA(DC)	VSS	VREF - 0.100	V
<b>DQ and DM</b>				
Input High (Logic 1) Voltage DDR3-800/1066/1333	VIHDQ(DC)	VREF + 0.100	VDD	V
Input Low (Logic 0) Voltage DDR3-800/1066/1333	VILDQ(DC)	VSS	VREF - 0.100	V

## Input AC Logic Level

All voltages referenced to VSS

Parameter	Symbol	Min	Max	Unit
<b>Command and Address</b>				
AC Input High (Logic 1) Voltage DDR3-800/1066/1333	VIHCA(AC)	VREF + 0.175	-	V
AC Input Low (Logic 0) Voltage DDR3-800/1066/1333	VILCA(AC)	-	VREF - 0.175	V
<b>DQ and DM</b>				
AC Input High (Logic 1) Voltage DDR3-800/1066	VIHDQ(AC)	VREF + 0.175	-	V
AC Input Low (Logic 0) Voltage DDR3-800/1066	VILDQ(AC)	-	VREF - 0.175	V
AC Input High (Logic 1) Voltage DDR3-1333	VIHDQ(AC)	VREF + 0.150	-	V
AC Input Low (Logic 0) Voltage DDR3-1333	VILDQ(AC)	-	VREF - 0.150	V

## Input/Output Capacitance

TA=25°C, f=100MHz

Parameter	Symbol	DDR3-800/1066		DDR3-1333		Unit
		Min	Max	Min	Max	
Input capacitance (A0~A13, BA0~BA2, RAS#, CAS#, WE#)	CIN1	16	28	16	24.8	pF
Input capacitance (CKE0, CKE1), (ODT0, ODT1), (CS0#, CS1#)	CIN2	10	16	10	14.4	pF
Input capacitance (CK0, CK0#, CK1, CK1#)	CIN3	10.4	16.8	10.4	15.2	pF
Input/Output capacitance (DQ, DQS, DQS#, DM, CB)	CIO	7	10/9.4	7	9	pF



# Product Specifications

PART NO:

VL47B5663A-K9S/F8S/E7S-I

REV: 1.0

## IDD Specification

Condition	Symbol	DDR3-1333 (-K9)	DDR3-1066 (-F8)	DDR3-800 (-E7)	Unit
<b>Operating one bank active-precharge current;</b> $t_{CK} = t_{CK(DD)}$ ; $t_{RC} = t_{RC(DD)}$ ; $t_{RAS} = t_{RAS(MIN(DD))}$ ; CKE is HIGH, CS# is HIGH between valid commands; Address bus inputs are SWITCHING; Data bus inputs are SWITCHING	IDD0*	840	800	720	mA
<b>Operating one bank active-read-precharge current;</b> IOU <sub>T</sub> = 0mA; BL = 8; CL = CL(DD); AL = 0; $t_{CK} = t_{CK(DD)}$ ; $t_{RC} = t_{RC(DD)}$ ; $t_{RAS} = t_{RAS(MIN(DD))}$ ; $t_{RCD} = t_{RCD(DD)}$ ; CKE is HIGH, CS# is HIGH between valid commands; Address bus inputs are SWITCHING; Data pattern is same as IDD4W.	IDD1*	1000	960	880	mA
<b>Precharge power-down current;</b> All banks idle; $t_{CK} = t_{CK(DD)}$ ; CKE is LOW; Other control and address bus inputs are STABLE; Data bus inputs are FLOATING	IDD2P-F**	160	160	160	mA
	IDD2P-S**	160	160	160	mA
<b>Precharge standby current;</b> All banks idle; $t_{CK} = t_{CK(DD)}$ ; CKE is HIGH; CS# is HIGH; Other control and address bus inputs are SWITCHING; Data bus inputs are SWITCHING	IDD2N**	720	640	560	mA
<b>Precharge quiet standby current;</b> All banks idle; $t_{CK} = t_{CK(DD)}$ ; CKE is HIGH; CS# is HIGH; Other control and address bus inputs are STABLE; Data bus inputs are FLOATING	IDD2Q**	720	640	560	mA
<b>Active power-down current;</b> All banks open; $t_{CK} = t_{CK(DD)}$ ; CKE is LOW; Other control and address bus inputs are STABLE; Data bus inputs are FLOATING	IDD3P**	960	800	720	mA
<b>Active standby current;</b> All banks open; $t_{CK} = t_{CK(DD)}$ ; $t_{RP} = t_{RP(DD)}$ ; $t_{RAS} = t_{RAS(MAX(DD))}$ ; CKE is HIGH, CS# is HIGH between valid commands; Other control and address bus inputs are SWITCHING; Data bus inputs are SWITCHING	IDD3N**	1280	1040	960	mA
<b>Operating burst read current;</b> All banks open; Continuous burst reads; IOU <sub>T</sub> = 0mA; BL = 8; CL = CL(DD); AL = 0; $t_{CK} = t_{CK(DD)}$ ; $t_{RAS} = t_{RAS(MAX(DD))}$ ; $t_{RB} = t_{RB(DD)}$ ; CKE is HIGH, CS# is HIGH between valid commands; Address bus inputs are SWITCHING; Data pattern is same as IDD4W.	IDD4R*	1760	1440	1200	mA
<b>Operating burst write current;</b> All banks open; Continuous burst writes; BL = 8; CL = CL(DD); AL = 0; $t_{CK} = t_{CK(DD)}$ ; $t_{RAS} = t_{RAS(MAX(DD))}$ ; $t_{RB} = t_{RB(DD)}$ ; CKE is HIGH, CS# is HIGH between valid commands; Address bus inputs are SWITCHING; Data bus inputs are SWITCHING	IDD4W*	1680	1360	1120	mA
<b>Burst refresh current;</b> $t_{CK} = t_{CK(DD)}$ ; Refresh command at every $t_{RFC(DD)}$ interval; CKE is HIGH; CS# is HIGH between valid commands; Other control and address bus inputs are SWITCHING; Data bus inputs are SWITCHING	IDD5**	3680	3360	3360	mA
<b>Self refresh current;</b> CK and CK# at 0V; CKE <sub>≤</sub> 0.2V; Other control and address bus inputs are FLOATING; Data bus inputs are FLOATING	IDD6**	160	160	160	mA
<b>Operating bank interleave read current;</b> All bank interleaving reads; IOU <sub>T</sub> = 0mA; BL = 8; CL = CL(DD); AL = $t_{RCD(DD)-1}$ ; $t_{CK} = t_{CK(DD)}$ ; $t_{RC} = t_{RC(DD)}$ ; $t_{RAS} = t_{RAS(DD)}$ ; $t_{RBD} = t_{RBD(DD)}$ ; $t_{RCD} = 1 * t_{CK(DD)}$ ; CKE is HIGH; CS# is HIGH between valid commands; Address bus inputs are STABLE during DESELECTs; Data pattern is same as IDD4R.	IDD7*	2640	2240	2080	mA

Note: IDD specification is based on Samsung D-die components.

\*: Value calculated as one module rank in this operating condition, and all other module ranks in IDD2P (CKE LOW) mode.

\*\* : Value calculated reflects all module ranks in this operating condition.



# Product Specifications

PART NO:

VL47B5663A-K9S/F8S/E7S-I

REV: 1.0

AC TIMING PARAMETERS & SPECIFICATIONS								
Parameter	Symbol	DDR3-1333 (-K9)		DDR3-1066 (-F8)		DDR3-800 (-E7)		Unit
		MIN	MAX	MIN	MAX	MIN	MAX	
<b>Clock Timing</b>								
Minimum Clock Cycle Time (DLL off mode)	tCK(DLL_OFF)	8	-	8	-	8	-	ns
Average Clock Period	tCK(avg)	See Speed Bins Table						ps
Clock Period	tCK(abs)	tCK(avg)min + tJIT(per)min	tCK(avg)max + tJIT(per)max	tCK(avg)min + tJIT(per)min	tCK(avg)max + tJIT(per)max	tCK(avg)min + tJIT(per)min	tCK(avg)max + tJIT(per)max	ps
Average high pulse width	tCH(avg)	0.47	0.53	0.47	0.53	0.47	0.53	tCK(avg)
Average low pulse width	tCL(avg)	0.47	0.53	0.47	0.53	0.47	0.53	tCK(avg)
Clock Period Jitter (Period)	tJIT(per)	-80	80	-90	90	-100	100	ps
Clock Period Jitter during DLL locking period	tJIT(per, lck)	-70	70	-80	80	-90	90	ps
Cycle to Cycle Period Jitter	tJIT(cc)	160		180		200		ps
Cycle to Cycle Period Jitter during DLL locking period	tJIT(cc, lck)	140		160		180		ps
Cumulative error across 2 cycles	tERR(2per)	-118	118	-132	132	-147	147	ps
Cumulative error across 3 cycles	tERR(3per)	-140	140	-157	157	-175	175	ps
Cumulative error across 4 cycles	tERR(4per)	-155	155	-175	175	-194	194	ps
Cumulative error across 5 cycles	tERR(5per)	-168	168	-188	188	-209	209	ps
Cumulative error across 6 cycles	tERR(6per)	-177	177	-200	200	-222	222	ps
Cumulative error across 7 cycles	tERR(7per)	-186	186	-209	209	-232	232	ps
Cumulative error across 8 cycles	tERR(8per)	-193	193	-217	217	-241	241	ps
Cumulative error across 9 cycles	tERR(9per)	-200	200	-224	224	-249	249	ps
Cumulative error across 10 cycles	tERR(10per)	-205	205	-231	231	-257	257	ps
Cumulative error across 11 cycles	tERR(11per)	-210	210	-237	237	-263	263	ps
Cumulative error across 12 cycles	tERR(12per)	-215	215	-242	242	-269	269	ps
Cumulative error across n = 13, 14 ... 49, 50 cycles	tERR(nper)	$tERR(nper)min = (1 + 0.68ln(n)) * tJIT(per)min$ $tERR(nper)max = (1 - 0.68ln(n)) * tJIT(per)max$						
Absolute clock HIGH pulse width	tCH(abs)	0.43		0.43		0.43		tCK(avg)
Absolute clock Low pulse width	tCL(abs)	0.43		0.43		0.43		tCK(avg)
<b>Data Timing</b>								
DQS,DQS to DQ skew, per group, per access	tDQSQ	-	125	-	150	-	200	ps
DQ output hold time from DQS, DQS	tQH	0.38	-	0.38	-	0.38	-	tCK(avg)
DQ low-impedance time from CK, CK	tLZ(DQ)	-500	250	-600	300	-800	400	ps
DQ high-impedance time from CK, CK	tHZ(DQ)	-	250	-	300	-	400	ps
Data setup time to DQS, DQS referenced to Vih(ac)/Vil(ac) levels	tDS(base)	-10	-	25	-	75	-	ps
Data hold time to DQS, DQS referenced to Vih(ac)/Vil(ac) levels	tDH(base)	65	-	100	-	150	-	ps



# Product Specifications

PART NO:

VL47B5663A-K9S/F8S/E7S-I

REV: 1.0

## AC TIMING PARAMETERS & SPECIFICATIONS

Parameter	Symbol	DDR3-1333 (-K9)		DDR3-1066 (-F8)		DDR3-800 (-E7)		Unit
		MIN	MAX	MIN	MAX	MIN	MAX	
<b>Data Strobe Timing</b>								
DQS, DQS READ Preamble	tRPRE	0.9	-	0.9	-	0.9	-	tCK
DQS, DQS differential READ Postamble	tRPST	0.3	-	0.3	-	0.3	-	tCK
DQS, DQS output high time	tQSH	0.4	-	0.38	-	0.38	-	tCK(avg)
DQS, DQS output low time	tQSL	0.4	-	0.38	-	0.38	-	tCK(avg)
DQS, DQS WRITE Preamble	tWPRE	0.9	-	0.9	-	0.9	-	tCK
DQS, DQS WRITE Postamble	tWPST	0.3	-	0.3	-	0.3	-	tCK
DQS, DQS rising edge output access time from rising CK, CK	tDQSCK	-255	255	-300	300	-400	400	ps
DQS, DQS low-impedance time (Referenced from RL-1)	tLZ(DQS)	-500	250	-600	300	-800	400	ps
DQS, DQS high-impedance time (Referenced from RL+BL/2)	tHZ(DQS)	-	250	-	300	-	400	ps
DQS, DQS differential input low pulse width	tDQSL	0.4	0.6	0.4	0.6	0.4	0.6	tCK
DQS, DQS differential input high pulse width	tDQSH	0.4	0.6	0.4	0.6	0.4	0.6	tCK
DQS, DQS rising edge to CK, CK rising edge	tDQSS	-0.25	0.25	-0.25	0.25	-0.25	0.25	tCK(avg)
DQS,DQS falling edge setup time to CK, CK rising edge	tDSS	0.2	-	0.2	-	0.2	-	tCK(avg)
DQS,DQS falling edge hold time to CK, CK rising edge	tDSH	0.2	-	0.2	-	0.2	-	tCK(avg)
<b>Command and Address Timing</b>								
DLL locking time	tDLLK	512	-	512	-	512	-	nCK
Internal READ Command to PRECHARGE Command delay	tRTP	max (4tCK,7.5ns)	-	max (4tCK,7.5ns)	-	max (4tCK,7.5ns)	-	
Delay from start of internal write transaction to internal read command	tWTR	max (4tCK,7.5ns)	-	max (4tCK,7.5ns)	-	max (4tCK,7.5ns)	-	
WRITE recovery time	tWR	15	-	15	-	15	-	ns
Mode Register Set command cycle time	tMRD	4	-	4	-	4	-	tCK(avg)
Mode Register Set command update delay	tMOD	max (12tCK,15ns)	-	max (12tCK,15ns)	-	max (12tCK,15ns)	-	
CAS# to CAS# command delay	tCCD	4	-	4	-	4	-	nCK
Auto precharge write recovery + precharge time	tDAL(min)			WR + roundup (tRP / tCK(AVG))				nCK
Multi-Purpose Register Recovery Time	tMPRR	1	-	1	-	1	-	nCK
ACTIVE to PRECHARGE command period	tRAS	36	70,000	37.5	70,000	37.5	70,000	ns
ACTIVE to ACTIVE command period for 1KB page size	tRRD	max (4tCK,6ns)	-	max (4tCK,7.5ns)	-	max (4tCK,10ns)	-	
ACTIVE to ACTIVE command period for 2KB page size	tRRD	max (4tCK,7.5ns)	-	max (4tCK,10ns)	-	max (4tCK,10ns)	-	
Four activate window for 1KB page size	tFAW	30	-	37.5	-	40	-	ns
Four activate window for 2KB page size	tFAW	45	-	50	-	50	-	ns
Command and Address setup time to CK, CK referenced to Vih(ac) / Vil(ac) levels	tS(base)	65	-	125	-	200	-	ps
Command and Address hold time from CK, CK referenced to Vih(ac) / Vil(ac) levels	tH(base)	140	-	200	-	275	-	ps



# Product Specifications

PART NO:

VL47B5663A-K9S/F8S/E7S-I

REV: 1.0

AC TIMING PARAMETERS & SPECIFICATIONS								
Parameter	Symbol	DDR3-1333 (-K9)		DDR3-1066 (-F8)		DDR3-800 (-E7)		Unit
		MIN	MAX	MIN	MAX	MIN	MAX	
<b>Refresh Timing</b>								
512Mb REFRESH to REFRESH OR REFRESH to ACTIVE command interval	tRFC	90	-	90	-	90	-	ns
1Gb REFRESH to REFRESH OR REFRESH to ACTIVE command interval	tRFC	110	-	110	-	110	-	ns
2Gb REFRESH to REFRESH OR REFRESH to ACTIVE command interval	tRFC	160	-	160	-	160	-	ns
4Gb REFRESH to REFRESH OR REFRESH to ACTIVE command interval	tRFC	300	-	300	-	300	-	ns
8Gb REFRESH to REFRESH OR REFRESH to ACTIVE command interval	tRFC	350	-	350	-	350	-	ns
Average periodic refresh interval (0°C ≤ TCASE ≤ 85 °C)	tREFI	7.8		7.8		7.8		us
Average periodic refresh interval (85°C ≤ TCASE ≤ 95 °C)	tREFI	3.9		3.9		3.9		us
<b>Calibration Timing</b>								
Power-up and RESET calibration time	tZQinit	512	-	512	-	512	-	tCK
Normal operation Full calibration time	tZQoper	256	-	256	-	256	-	tCK
Normal operation Short calibration time	tZQCS	64	-	64	-	64	-	tCK
<b>Reset Timing</b>								
Exit Reset from CKE HIGH to a valid command	tXPR	max(5tCK, tRFC + 10ns)	-	max(5tCK, tRFC + 10ns)	-	max(5tCK, tRFC + 10ns)	-	
<b>Self Refresh Timing</b>								
Exit Self Refresh to commands not requiring a locked DLL	tXS	max(5tCK, tRFC + 10ns)	-	max(5tCK, tRFC + 10ns)	-	max(5tCK, tRFC + 10ns)	-	
Exit Self Refresh to commands requiring a locked DLL	tXSDLL	tDLLK(min)	-	tDLLK(min)	-	tDLLK(min)	-	tCK
Minimum CKE low width for Self refresh entry to exit timing	tCKESR	tCKE(min) + 1tCK	-	tCKE(min) + 1tCK	-	tCKE(min) + 1tCK	-	
Valid Clock Requirement after Self Refresh Entry (SRE)	tCKSRE	max(5tCK, 10ns)	-	max(5tCK, 10ns)	-	max(5tCK, 10ns)	-	
Valid Clock Requirement before Self Refresh Exit (SRX)	tCKSRX	max(5tCK, 10ns)	-	max(5tCK, 10ns)	-	max(5tCK, 10ns)	-	
<b>Power Down Timing</b>								
Exit Power Down with DLL to any valid command; Exit Precharge Power Down with DLL frozen to commands not requiring a locked DLL	tXP	max(3tCK, 6ns)	-	max(3tCK, 7.5ns)	-	max(3tCK, 7.5ns)	-	
Exit Precharge Power Down with DLL frozen to commands requiring a locked DLL	tXPDLL	max(10tCK, 24ns)	-	max(10tCK, 24ns)	-	max(10tCK, 24ns)	-	
CKE minimum pulse width	tCKE	max(3tCK, 5.625ns)	-	max(3tCK, 5.625ns)	-	max(3tCK, 7.5ns)	-	
Command pass disable delay	tCPDED	1	-	1	-	1	-	nCK



# Product Specifications

PART NO:

VL47B5663A-K9S/F8S/E7S-I

REV: 1.0

## AC TIMING PARAMETERS & SPECIFICATIONS

Parameter	Symbol	DDR3-1333 (-K9)		DDR3-1066 (-F8)		DDR3-800 (-E7)		Unit
		MIN	MAX	MIN	MAX	MIN	MAX	
Power Down Entry to Exit Timing	tPD	tCKE(min)	9*tREFI	tCKE(min)	9*tREFI	tCKE(min)	9*tREFI	tCK
Timing of ACT command to Power Down entry	tACTPDEN	1	-	1	-	1	-	nCK
Timing of PRE command to Power Down entry	tPRPDEN	1	-	1	-	1	-	nCK
Timing of RD/RDA command to Power Down entry	tRDPDEN	RL + 4 + 1	-	RL + 4 + 1	-	RL + 4 + 1	-	
Timing of WR command to Power Down entry (BL8OTF, BL8MRS, BL4OTF)	tWRPDEN	WL + 4 +(tWR/tCK)	-	WL + 4 +(tWR/tCK)	-	WL + 4 +(tWR/tCK)	-	nCK
Timing of WRA command to Power Down entry (BL8OTF, BL8MRS, BL4OTF)	tWRAPDEN	WL + 4 +WR +1	-	WL + 4 +WR +1	-	WL + 4 +WR +1	-	nCK
Timing of WR command to Power Down entry (BL4MRS)	tWRPDEN	WL + 2 +(tWR/tCK)	-	WL + 2 +(tWR/tCK)	-	WL + 2 +(tWR/tCK)	-	nCK
Timing of WRA command to Power Down entry (BL4MRS)	tWRAPDEN	WL +2 +WR +1	-	WL +2 +WR +1	-	WL +2 +WR +1	-	nCK
Timing of REF command to Power Down entry	tREFPDEN	1	-	1	-	1	-	
Timing of MRS command to Power Down entry	tMRSPDEN	tMOD(min)	-	tMOD(min)	-	tMOD(min)	-	tCK
<b>ODT Timing</b>								
ODT high time without write command or with write command and BC4	ODTH4	4	-	4	-	4	-	nCK
ODT high time with Write command and BL8	ODTH8	6	-	6	-	6	-	nCK
Asynchronous RTT turn-on delay (Power-Down with DLL frozen)	tAONPD	1	9	1	9	1	9	ns
Asynchronous RTT turn-off delay (Power-Down with DLL frozen)	tAOPFD	1	9	1	9	1	9	ns
ODT turn-on	tAON	-250	250	-300	300	-400	400	ps
RTT_NOM and RTT_WR turn-off time from ODTLoff reference	tAOF	0.3	0.7	0.3	0.7	0.3	0.7	tCK(avg)
RTT dynamic change skew	tADC	0.3	0.7	0.3	0.7	0.3	0.7	tCK(avg)
<b>Write Leveling Timing</b>								
First DQS pulse rising edge after tDQSS margining mode is programmed	tWLMRD	40	-	40	-	40	-	tCK
DQS/DQS delay after tDQSS margining mode is programmed	tWLDQSEN	25	-	25	-	25	-	tCK
Setup time for tDQSS latch	tWLS	195	-	245	-	325	-	ps
Hold time for tDQSS latch	tWLH	195	-	245	-	325	-	ps
Write leveling output delay	tWLO	0	9	0	9	0	9	ns
Write leveling output error	tWLOE	0	2	0	2	0	2	ns

<b>Product Specifications</b>		
PART NO:	VL47B5663A-K9S/F8S/E7S-I	REV: 1.0

### Package Dimensions

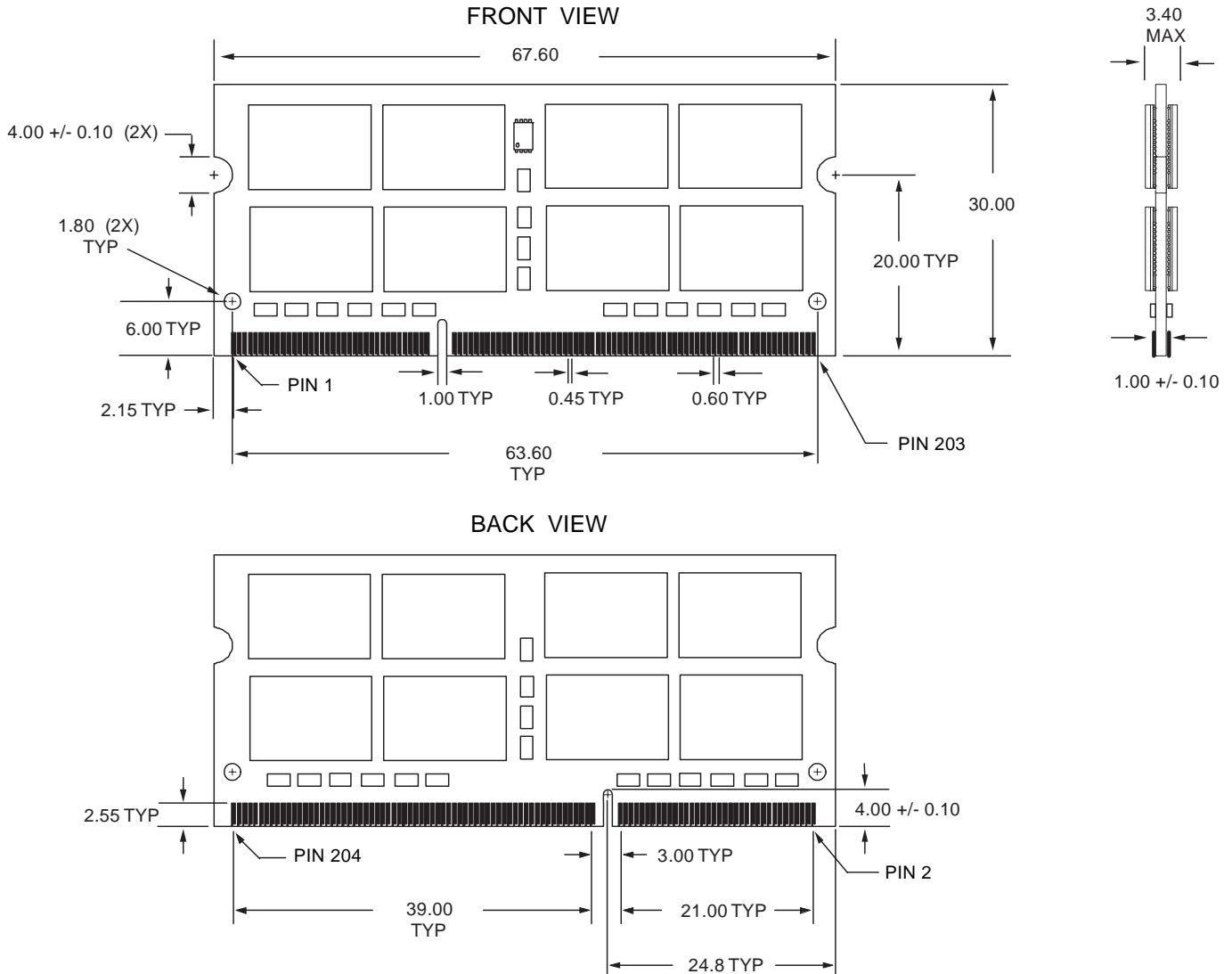

**Notes:**

All dimensions are in millimeters with tolerance +/- 0.15mm unless otherwise specified.



<b>Product Specifications</b>		
<b>PART NO:</b>	<b>VL47B5663A-K9S/F8S/E7S-I</b>	<b>REV: 1.0</b>

**Revision History:**

<b>Date</b>	<b>Rev.</b>	<b>Page</b>	<b>Changes</b>
03/25/09	1.0	All	First release