



Product Specifications

PART NO:

VL470T5663B-E6S/D5S/CCS-I

REV: 1.1

General Information

2GB 256Mx64 DDR2 SDRAM NON-ECC UNBUFFERED SODIMM 200-PIN

Description: The VL470T5663B is a 256M X 64 DDR2 SDRAM high density SODIMM. This memory module consists of sixteen CMOS 128M X 8 bit with 8 banks DDR2 Synchronous DRAMs in BGA packages and a 2K EEPROM in an 8-pin TSSOP package. This module is a 200-pin small-outline dual in-line memory module and is intended for mounting into a connector socket. Decoupling capacitors are mounted on the printed circuit board for each DDR2 SDRAM.

Features:

- . 200-pin, small-outline dual in-line memory module (SODIMM)
- . Fast data transfer rates: PC2-5300, PC2-4200, and PC2-3200
- . VDD = VDDQ = 1.8V
- . VDDSPD = 1.7V to 3.6V
- . JEDEC standard 1.8V I/O (SSTL_18 compatible)
- . Differential data strobe (DQS, DQS#) option
- . Four-bit prefetch architecture
- . DLL aligns DQ and DQS transition with CK
- . Programmable CAS# Latency (CL): 5 (DDR2-667), 4 (DDR2-533), 3 (DDR2-400)
- . Programmable burst; length (4, 8)
- . On-die termination (ODT)
- . Auto & Self refresh, (8K/64ms refresh)
- . Serial presence detect (SPD) with EEPROM
- . Gold edge PCB contacts
- . Lead-free, RoHS compliant
- . PCB: Height 30.00mm (1.181"), double sided components
- . Operating temperature (T_{OPER}): -40°C to +85°C (module screening using commercial DRAM)

Pin Name	Function
A0~A13	Address Inputs
BA0~BA2	Bank Address Inputs
DQ0~DQ63	Data Input/Output
DQS0~DQS7	Data Strobes
DQS0#~DQS7#	Data Strobes Complement
ODT0,ODT1	On-die Termination Control
CK0,CK0#,CK1,CK1#	Clock Input
CKE0,CKE1	Clock Enables
CS0#,CS1#	Chip Selects
RAS#	Row Address Strobes
CAS#	Column Address Strobes
WE#	Write Enable
VDD	Voltage Supply 1.8V +/- 0.1V
VSS	Ground
SA0~SA1	SPD Address
SDA	SPD Data Input/Output
SCL	SPD Clock Input
DM0~DM7	Data Masks
A10/AP	Address Input/Autoprecharge
VREF	SSTL_18 Reference Voltage
VDDSPD	SPD Voltage Supply 1.7V to 3.6V
NC	No Connect

Order Information:

VL470T5663B-E6 S X-I

I: Screening temperature

DRAM DIE (option)

DRAM MANUFACTURER
S - SAMSUNG

MODULE SPEED

E6: PC2-5300 @ CL5

D5: PC2-4200 @ CL4

CC: PC2-3200 @ CL3

VL : Lead-free/RoHS



Product Specifications

PART NO:

VL470T5663B-E6S/D5S/CCS-I

REV: 1.1

Pin Configuration

200-PIN DDR2 SODIMM FRONT								200-PIN DDR2 SODIMM BACK							
Pin	Name	Pin	Name	Pin	Name	Pin	Name	Pin	Name	Pin	Name	Pin	Name		
1	VREF	51	DQS2	101	A1	151	DQ42	2	VSS	52	DM2	102	A0	152	DQ46
3	VSS	53	VSS	103	VDD	153	DQ43	4	DQ4	54	VSS	104	VDD	154	DQ47
5	DQ0	55	DQ18	105	A10/AP	155	VSS	6	DQ5	56	DQ22	106	BA1	156	VSS
7	DQ1	57	DQ19	107	BA0	157	DQ48	8	VSS	58	DQ23	108	RAS#	158	DQ52
9	VSS	59	VSS	109	WE#	159	DQ49	10	DM0	60	VSS	110	CS0#	160	DQ53
11	DQS0#	61	DQ24	111	VDD	161	VSS	12	VSS	62	DQ28	112	VDD	162	VSS
13	DQS0	63	DQ25	113	CAS#	163	NC	14	DQ6	64	DQ29	114	OTD0	164	CK1
15	VSS	65	VSS	115	CS1#	165	VSS	16	DQ7	66	VSS	116	A13	166	CK1#
17	DQ2	67	DM3	117	VDD	167	DQS6#	18	VSS	68	DQS3#	118	VDD	168	VSS
19	DQ3	69	NC	119	ODT1	169	DQS6	20	DQ12	70	DQS3	120	NC	170	DM6
21	VSS	71	VSS	121	VSS	171	VSS	22	DQ13	72	VSS	122	VSS	172	VSS
23	DQ8	73	DQ26	123	DQ32	173	DQ50	24	VSS	74	DQ30	124	DQ36	174	DQ54
25	DQ9	75	DQ27	125	DQ33	175	DQ51	26	DM1	76	DQ31	126	DQ37	176	DQ55
27	VSS	77	VSS	127	VSS	177	VSS	28	VSS	78	VSS	128	VSS	178	VSS
29	DQS1#	79	CKE0	129	DQS4#	179	DQ56	30	CK0	80	CKE1	130	DM4	180	DQ60
31	DQS1	81	VDD	131	DQS4	181	DQ57	32	CK0#	82	VDD	132	VSS	182	DQ61
33	VSS	83	NC	133	VSS	183	VSS	34	VSS	84	NC	134	DQ38	184	VSS
35	DQ10	85	BA2	135	DQ34	185	DM7	36	DQ14	86	NC	136	DQ39	186	DQS7#
37	DQ11	87	VDD	137	DQ35	187	VSS	38	DQ15	88	VDD	138	VSS	188	DQS7
39	VSS	89	A12	139	VSS	189	DQ58	40	VSS	90	A11	140	DQ44	190	VSS
41	VSS	91	A9	141	DQ40	191	DQ59	42	VSS	92	A7	142	DQ45	192	DQ62
43	DQ16	93	A8	143	DQ41	193	VSS	44	DQ20	94	A6	144	VSS	194	DQ63
45	DQ17	95	VDD	145	VSS	195	SDA	46	DQ21	96	VDD	146	DQS5#	196	VSS
47	VSS	97	A5	147	DM5	197	SCL	48	VSS	98	A4	148	DQS5	198	SA0
49	DQS2#	99	A3	149	VSS	199	VDDSPD	50	NC	100	A2	150	VSS	200	SA1



Product Specifications

PART NO:

VL470T5663B-E6S/D5S/CCS-I

REV: 1.1

Functional Block Diagram

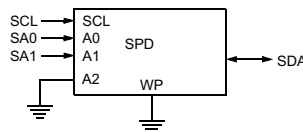
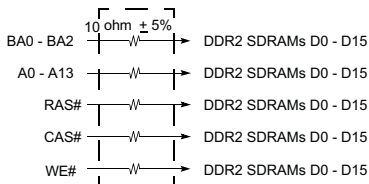
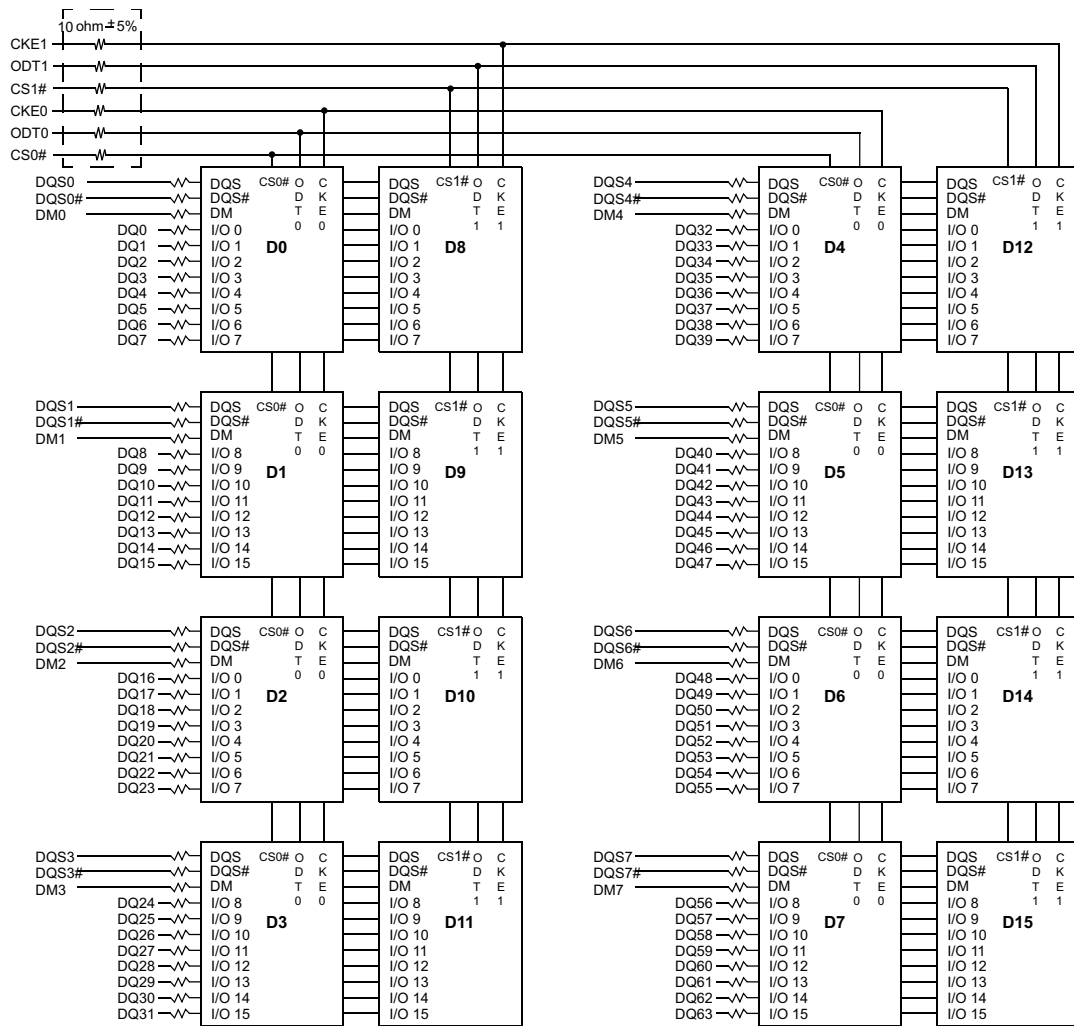

* Clock Wiring	
Clock Input	DDR2 SDRAMs
*CK0/CK0#	8 DDR2 SDRAMs
*CK1/CK1#	8 DDR2 SDRAMs

* Wire per Clock Loading Table/Wiring Diagrams

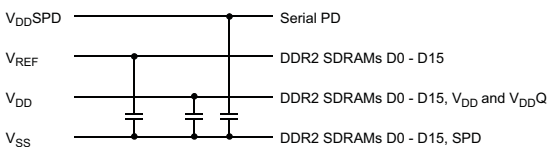

Notes :

1. DQ,DM, DQS/DQS# resistors : 22 Ohms +/- 5%



Product Specifications

PART NO:

VL470T5663B-E6S/D5S/CCS-I

REV: 1.1

Absolute Maximum Ratings

Symbol	Parameter	MIN	MAX	Unit	
VDD	Voltage on VDD pin relative to Vss	-1.0	2.3	V	
VDDQ	Voltage on VDDQ pin relative to Vss	-0.5	2.3	V	
VDDL	Voltage on VDDL pin relative to Vss	-0.5	2.3	V	
VIN, VOUT	Voltage on any pin relative to Vss	-0.5	2.3	V	
TSTG	Storage temperature	-55	100	°C	
IL	Input leakage current; Any input 0V<VIN<VDD; VREF input 0V<VIN<0.95V; Other pins not under test = 0V	Command/Address, RAS#, CAS#, WE#, BA	-80	80	uA
		CS#, CKE	-40	40	uA
		CK, CK#	-40	40	uA
		DM	-10	10	uA
Ioz	Output leakage current; 0V<VOUT<VDDQ; DQs and ODT are disabled	-10	10	uA	
IREF	VREF leakage current; VREF = Valid VREF level	-32	32	uA	

DC Operating Conditions

All voltages referenced to VSS

Parameter	Symbol	Min	Typical	Max	Unit	Notes
Supply voltage	VDD	1.7	1.8	1.9	V	1
I/O Supply voltage	VDDQ	1.7	1.8	1.9	V	4
VDDL Supply voltage	VDDL	1.7	1.8	1.9	V	4
I/O Reference voltage	VREF	0.49 x VDDQ	0.50 x VDDQ	0.51 x VDDQ	V	2
I/O Termination voltage	VTT	VREF-0.04	VREF	VREF+0.04	V	3

- Notes:
1. VDD, VDDQ must track each other. VDDQ must be less than or equal to VDD.
 2. VREF is expected to equal VDDQ/2 of the transmitting device and to track variations in the DC level of the same. Peak-to-peak noise on VREF may not exceed +/-1 percent of the DC value. Peak-to-peak AC noise on VREF may not exceed +/-2 percent of VREF. This measurement is to be taken at the nearest VREF bypass capacitor.
 3. VTT is not applied directly to the device. VTT is a system supply for signal termination resistors, is expected to be set equal to VREF and must track variations in the DC level of VREF.
 4. VDDQ tracks with VDD; VDDL tracks with VDD.



Product Specifications

PART NO:

VL470T5663B-E6S/D5S/CCS-I

REV: 1.1

Operating Temperature Condition

Parameter	Symbol	Rating	Units	Notes
Operating temperature	TOPER	-40 to +85	°C	1,2

Notes:

1. Operating temperature is the case surface temperature on the center/top side of the DRAM. For the measurement conditions, please refer to JEDEC JESD51 2
2. At -40 to +85°C, operation temperature range, all DRAM specifications will be supported.

Input DC Logic Level

All voltages referenced to VSS

Parameter	Symbol	Min	Max	Unit
Input High (Logic 1) Voltage	VIH(DC)	VREF + 0.125	VDDQ + 0.300	V
Input Low (Logic 0) Voltage	VIL(DC)	-0.300	VREF - 0.125	V

Input AC Logic Level

All voltages referenced to VSS

Parameter	Symbol	Min	Max	Unit
AC Input High (Logic 1) Voltage DDR2-400 & DDR2-533	VIH(AC)	VREF + 0.250	-	V
AC Input High (Logic 1) Voltage DDR2-667	VIH(AC)	VREF + 0.200	-	V
AC Input Low (Logic 0) Voltage DDR2-400 & DDR2-533	VIL(AC)	-	VREF - 0.250	V
AC Input Low (Logic 0) Voltage DDR2-667	VIL(AC)	-	VREF - 0.200	V

Input/Output Capacitance

TA=25°C, f=100MHz

Parameter	Symbol	Min	Max	Unit
Input capacitance (A0~A13, BA0~BA2, RAS#, CAS#, WE#)	CIN1	20	36	pF
Input capacitance (CKE0, CKE1), (ODT0, ODT1)	CIN2	12	20	pF
Input capacitance (CS0#, CS1#)	CIN3	12	20	pF
Input capacitance (CK0, CK0#, CK1, CK1#)	CIN4	12	20	pF
Input capacitance (DM0 ~ DM7)	CIN5 (E6)	9	11	pF
	CIN5 (D5,CC)	9	12	pF
Input capacitance (DQ0 ~ DQ63), (DQS0 ~ DQS7)	COUT1 (E6)	9	11	pF
	COUT1 (D5,CC)	9	12	pF



Product Specifications

PART NO:

VL470T5663B-E6S/D5S/CCS-I

REV: 1.1

IDD Specification

Condition	Symbol	-E6	-D5	-CC	Unit	
Operating one bank active-precharge; $t_{CK} = t_{CK(IDD)}$; $t_{RC} = t_{RC(IDD)}$; $t_{RAS} = t_{RAS MIN(IDD)}$; CE is HIGH, CS# is HIGH between valid commands; Address bus inputs are SWITCHING; Data bus inputs are SWITCHING	IDD0*	800	760	720	mA	
Operating one bank active-read-precharge; IOUT = 0mA; BL = 4; CL = CL(IDD); $t_{CK} = t_{CK(IDD)}$; $t_{RC} = t_{RC(IDD)}$; $t_{RAS} = t_{RAS MIN(IDD)}$; CE is HIGH, CS# is HIGH between valid commands; Address bus inputs are SWITCHING; Data bus inputs are SWITCHING; Data pattern is same as IDD4W.	IDD1*	880	840	800	mA	
Precharge power-down current; All banks idle; $t_{CK} = t_{CK(IDD)}$; CE is LOW; Other control and address bus inputs are STABLE; Data bus inputs are FLOATING	IDD2P**	240	240	240	mA	
Precharge quiet standby current; All banks idle; $t_{CK} = t_{CK(IDD)}$; CE is HIGH; CS# is HIGH; Other control and address bus inputs are STABLE; Data bus inputs are FLOATING	IDD2Q**	640	640	560	mA	
Precharge standby current; All banks idle; $t_{CK} = t_{CK(IDD)}$; CE is HIGH; CS# is HIGH; Other control and address bus inputs are STABLE; Data bus inputs are SWITCHING.	IDD2N**	720	720	640	mA	
Active power-down current; All banks open; $t_{CK} = t_{CK(IDD)}$; CE is LOW; Other control and address bus inputs are STABLE; Data bus inputs are FLOATING.	Fast PDN Exit MRS(12) = 0	IDD3P**	640	560	560	mA
		Slow PDN Exit MRS(12) = 1	288	288	288	mA
Active standby current; All banks open; $t_{CK} = t_{CK(IDD)}$; $t_{RC} = t_{RC(IDD)}$; $t_{RAS} = t_{RAS MIN(IDD)}$; CE is HIGH, CS# is HIGH between valid commands; Other control and address bus inputs are SWITCHING; Data bus inputs are SWITCHING.	IDD3N**	960	960	880	mA	
Operating burst write current; All banks open; Continuous burst writes; BL = 4; CL = CL(IDD); AL = 0; $t_{CK} = t_{CK(IDD)}$; $t_{RAS} = t_{RAS MAX(IDD)}$; $t_{RP} = t_{RP(IDD)}$; CE is HIGH, CS# is HIGH between valid commands; Address bus inputs are SWITCHING; Data bus inputs are SWITCHING.	IDD4W*	1160	1080	960	mA	
Operating burst read current; All banks open; Continuous burst reads; IOUT = 0mA; BL = 4; CL = CL(IDD); AL = 0; $t_{CK} = t_{CK(IDD)}$; $t_{RAS} = t_{RAS MAX(IDD)}$; $t_{RP} = t_{RP(IDD)}$; CE is HIGH, CS# is HIGH between valid commands; Address bus inputs are SWITCHING; Data pattern is same as IDD4W.	IDD4R*	1240	1160	1040	mA	
Burst auto refresh current; $t_{CK} = t_{CK(IDD)}$; Refresh command at every $t_{RC(IDD)}$ interval; CE is HIGH; CS# is HIGH between valid commands; Other control and address bus inputs are SWITCHING; Data bus inputs are SWITCHING.	IDD5**	2400	2400	2320	mA	
Self refresh current; CK and CK# at 0V; CE < 0.2V; Other control and address bus inputs are FLOATING; Data bus inputs are FLOATING.	Normal	IDD6**	240	240	240	mA
Operating bank interleave read current; All bank interleaving reads; IOUT = 0mA; BL = 4; CL = CL(IDD); AL = $t_{RCD(IDD)} - 1 * t_{CK(IDD)}$; $t_{CK} = t_{CK(IDD)}$; $t_{RC} = t_{RC(IDD)}$; $t_{RRD} = t_{RRD(IDD)}$; $t_{RCD} = 1 * t_{CK(IDD)}$; CE is HIGH; CS# is HIGH between valid commands; Address bus inputs are STABLE during DESELECTs; Data bus inputs are SWITCHING.	IDD7*	2040	2040	1920	mA	

Notes:

IDD specification is based on Samsung components. Other DRAM Manufacturers specification may be different.

*: Value calculated as one module rank in this operating condition, and all other module ranks in IDD2P (CE LOW) mode.

** : Value calculated reflects all module ranks in this operating condition.



Product Specifications

PART NO:

VL470T5663B-E6S/D5S/CCS-I

REV: 1.1

AC Timing Parameters & Specifications

Parameter		Symbol	-E6		-D5		-CC		Unit	
			Min	Max	Min	Max	Min	Max		
Clock	Clock cycle time	CL=5	$t_{CK}(5)$	3000	8000	-	-	-	-	ps
		CL=4	$t_{CK}(4)$	3750	8000	3,750	8,000	5,000	8,000	ps
		CL=3	$t_{CK}(3)$	5000	8000	5,000	8,000	5,000	8,000	ps
	CK high-level width	t_{CH}	0.45	0.55	0.45	0.55	0.45	0.55	t_{CK}	
	CK low-level width	t_{CL}	0.45	0.55	0.45	0.55	0.45	0.55	t_{CK}	
	Half clock period	t_{HP}	MIN		MIN		MIN			ps
			(t_{CH}, t_{CL})			(t_{CH}, t_{CL})			(t_{CH}, t_{CL})	
	Clock jitter	t_{JIT}	-125	125	-125	125	-125	125	ps	
Data	DQ output access time from CK/CK#	t_{AC}	-450	+450	-500	+500	-600	+600	ps	
	Data-out high impedance window from CK/CK#	t_{HZ}		$t_{AC(MAX)}$		$t_{AC(MAX)}$		$t_{AC(MAX)}$	ps	
	Data-out low-impedance window from CK/CK#	t_{LZ}	$t_{AC(MIN)}$	$t_{AC(MAX)}$	$t_{AC(MIN)}$	$t_{AC(MAX)}$	$t_{AC(MIN)}$	$t_{AC(MAX)}$	ps	
	DQ and DM input setup time relative to DQS	t_{DS}	100		100		150			
	DQ and DM input hold time relative to DQS	t_{DH}	175		225		275			
	DQ and DM input pulse width (for each input)	t_{DIPW}	0.35		0.35		0.35		t_{CK}	
	Data hold skew factor	t_{QHS}		340		400		450	ps	
	DQ-DQS hold, DQS to first DQ to go nonvalid, per access	t_{QH}	$t_{HP} - t_{QHS}$		$t_{HP} - t_{QHS}$		$t_{HP} - t_{QHS}$		ps	
	Data valid output window (DVW)	t_{DVW}	$t_{QH} - t_{DQSQ}$		$t_{QH} - t_{DQSQ}$		$t_{QH} - t_{DQSQ}$		ns	
Data Strobe	DQS input high pulse width	t_{DQSH}	0.35		0.35		0.35		t_{CK}	
	DQS input low pulse width	t_{DQSL}	0.35		0.35		0.35		t_{CK}	
	DQS output access time from CK/CK#	t_{DQSCK}	-400	+400	-450	+450	-500	+500	ps	
	DQS falling edge to CK rising – setup time	t_{DSS}	0.2		0.2		0.2		t_{CK}	
	DQS falling edge from CK rising – hold time	t_{DSH}	0.2		0.2		0.2		t_{CK}	
	DQS-DQ skew, DQS to last DQ valid, per group, per access	t_{DQSQ}		240		300		350	ps	
	DQS read preamble	t_{RPRE}	0.9	1.1	0.9	1.1	0.9	1.1	t_{CK}	
	DQS read postamble	t_{RPST}	0.4	0.6	0.4	0.6	0.4	0.6	t_{CK}	
	DQS write preamble setup time	t_{WPRES}	0		0		0		ps	
	DQS write preamble	t_{WPRE}	0.35		0.35		0.35		t_{CK}	
	DQS write postamble	t_{WPST}	0.4	0.6	0.4	0.6	0.4	0.6	t_{CK}	
	Write command to first DQS latching transition	t_{DQSS}	WL-0.25	WL+0.25	WL-0.25	WL+0.25	WL-0.25	WL+0.25	t_{CK}	



Product Specifications

PART NO:

VL470T5663B-E6S/D5S/CCS-I

REV: 1.1

AC Timing Parameters & Specifications (cont')									
Parameter	Symbol	-E6		-D5		-CC		Unit	
		Min	Max	Min	Max	Min	Max		
Command and Address	Address and control input pulse width for each input	t_{PW}	0.6		0.6		0.6		t_{CK}
	Address and control input setup time	t_{IS}	200		250		350		ps
	Address and control input hold time	t_{IH}	275		375		475		ps
	CAS# to CAS# command delay	t_{CCD}	2		2		2		ps
	ACTIVE to ACTIVE (same bank) command	t_{RC}	55		55		55		ns
	ACTIVE bank a to ACTIVE bank b command	t_{RRD}	7.5		7.5		7.5		ns
	ACTIVE to READ or WRITE delay	t_{RCD}	15		15		15		ns
	Four Bank Activate period	t_{FAW}	37.5	37.5	37.5	37.5	37.5	37.5	ns
	ACTIVE to PRECHARGE command	t_{RAS}	40	70,000	40	70,000	40	70,000	ns
	Internal READ to precharge command delay	t_{RTP}	7.5		7.5		7.5		ns
	Write recovery time	t_{WR}	15		15		15		ns
	Auto precharge write recovery + precharge time	t_{DAL}	$t_{WR}+t_{RP}$		$t_{WR}+t_{RP}$		$t_{WR}+t_{RP}$		ns
	Internal WRITE to READ command delay	t_{WTR}	7.5		7.5		10		ns
	PRECHARGE command period	t_{RP}	15		15		15		ns
	PRECHARGE ALL command period	t_{RPA}	$t_{RP}+t_{CK}$		$t_{RP}+t_{CK}$		$t_{RP}+t_{CK}$		ns
	LOAD MODE command cycle time	t_{MRD}	2		2		2		t_{CK}
	CKE low to CK,CK# uncertainty	t_{DELAY}	$t_{IS}+t_{CK}+t_{IH}$		$t_{IS}+t_{CK}+t_{IH}$		$t_{IS}+t_{CK}+t_{IH}$		ns
Self Refresh	REFRESH to Active or Refresh to Refresh command interval	t_{RFC}	127.5	70,000	127.5	70,000	127.5	70,000	ns
	Average periodic refresh interval	t_{REFI}		7.8		7.8		7.8	us
	Exit self refresh to non-READ command	t_{XSNR}	$t_{RFC(MIN)}+10$		$t_{RFC(MIN)}+10$		$t_{RFC(MIN)}+10$		ns
	Exit self refresh to READ	t_{XSRD}	200		200		200		t_{CK}
	Exit self refresh timing reference	t_{ISXR}	t_{IS}		t_{IS}		t_{IS}		ps
ODT	ODT turn-on delay	t_{AOND}	2	2	2	2	2	2	t_{CK}
	ODT turn-on	t_{AON}	$t_{AC(MIN)}$	$t_{AC(MAXI)}+700$	$t_{AC(MIN)}$	$t_{AC(MAXI)}+1000$	$t_{AC(MIN)}$	$t_{AC(MAXI)}+1000$	ps
	ODT turn-off delay	t_{AOFD}	2.5	2.5	2.5	2.5	2.5	2.5	t_{CK}
	ODT turn-off	t_{AOF}	$t_{AC(MIN)}$	$t_{AC(MAXI)}+600$	$t_{AC(MIN)}$	$t_{AC(MAXI)}+600$	$t_{AC(MIN)}$	$t_{AC(MAXI)}+600$	ps
	ODT turn-on (power-down mode)	t_{AONPD}	$t_{AC(MIN)}+2000$	$2 \times t_{CK} + t_{AC(MAXI)}+1000$	$t_{AC(MIN)}+2000$	$2 \times t_{CK} + t_{AC(MAXI)}+1000$	$t_{AC(MIN)}+2000$	$2 \times t_{CK} + t_{AC(MAXI)}+1000$	ps
	ODT turn-off (power-down mode)	t_{AOFPD}	$t_{AC(MIN)}+2000$	$2.5 \times t_{CK} + t_{AC(MAXI)}+1000$	$t_{AC(MIN)}+2000$	$2.5 \times t_{CK} + t_{AC(MAXI)}+1000$	$t_{AC(MIN)}+2000$	$2.5 \times t_{CK} + t_{AC(MAXI)}+1000$	ps
	ODT to power-down entry latency	t_{ANPD}	3		3		3		t_{CK}
	ODT power-down exit latency	t_{AXPD}	8		8		8		t_{CK}
Power-Down	Exit active power-down to READ command, MR[bit12=0]	t_{XARD}	2		2		2		t_{CK}
	Exit active power-down to READ command, MR[bit12=1]	t_{XARDS}	7-AL		6-AL		6-AL		t_{CK}
	Exit precharge power-down to any non-READ command.	t_{XP}	2		2		2		t_{CK}
	CKE minimum high/low time	t_{CKE}	3		3		3		t_{CK}

<h1>Product Specifications</h1>		
PART NO:	VL470T5663B-E6S/D5S/CCS-I	REV: 1.1

Package Dimensions

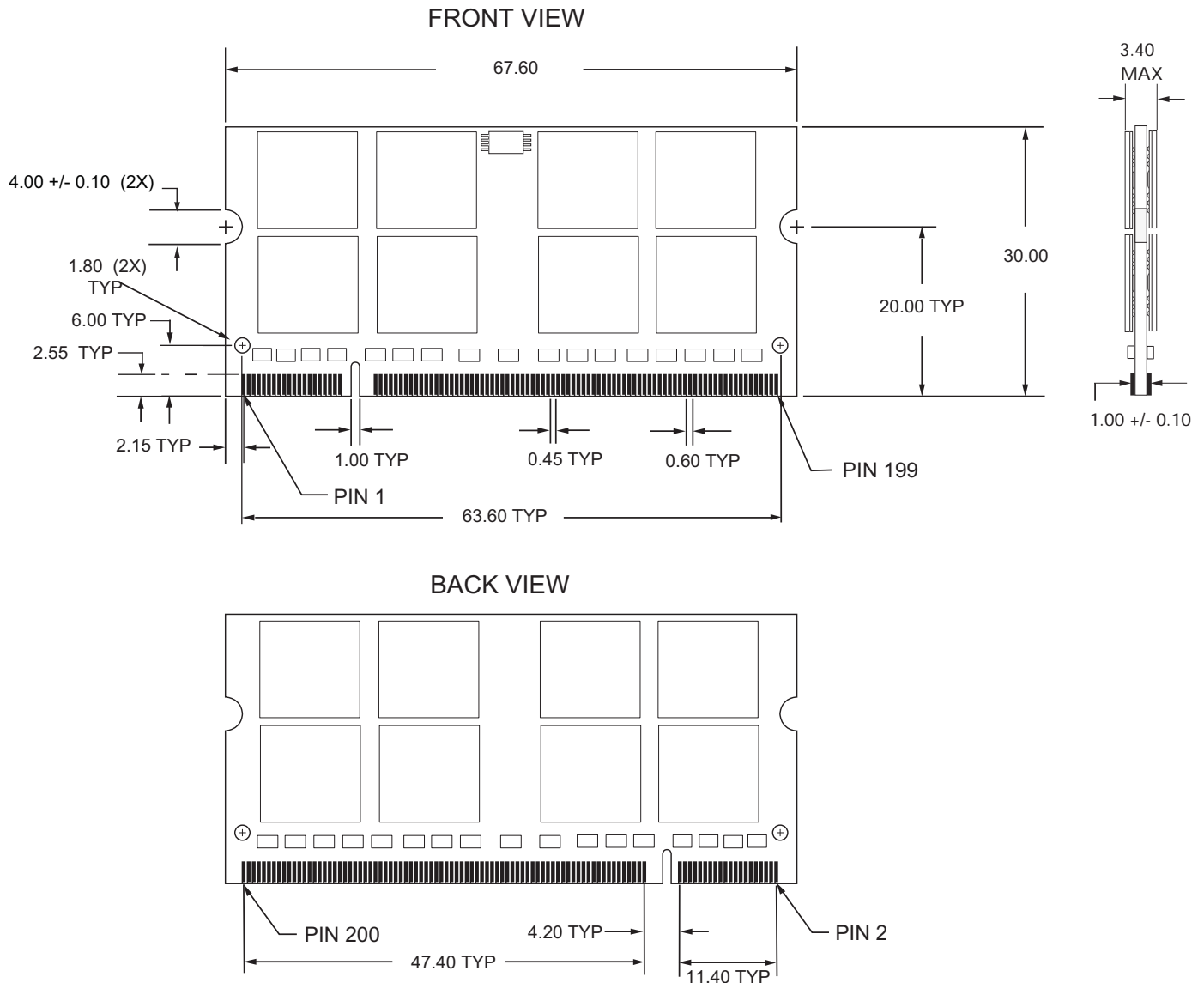

NOTE:
All dimensions are in millimeters with tolerance +/- 0.15mm unless otherwise specified.



Product Specifications

PART NO:

VL470T5663B-E6S/D5S/CCS-I

REV: 1.1

Revision History:

Date	Rev.	Page	Changes
05/18/09	1.0	All	Spec release
08/25/10	1.1	All	Update datasheet